

SME

M6DEL

INTEGRATED PRECISION TURNTABLE

OWNERS MANUAL

M6DEL

INTEGRATED PRECISION TURNTABLE

Instructions

This is no ordinary turntable.

These instructions include unpacking, set up procedures and specifications.

Please read carefully.



Warning! Important Safety Instructions

CAUTION: RISK OF ELECTRIC SHOCK DO NOT REMOVE POWER UNIT COVER.

CAUTION: TO REDUCE THE RISK OF ELECTRIC SHOCK, DO NOT REMOVE THE SPEED CONTROL UNIT (POWER UNIT) COVER. THERE ARE NO USER SERVICEABLE PARTS INSIDE. REFER ALL SERVICING TO QUALIFIED PERSONNEL.

- Please read this manual carefully and keep it in a safe place for future reference.
- The vent slots in the underside of the Speed Control Unit are for necessary ventilation. To ensure reliable operation of this apparatus and to protect from overheating these vents must never be blocked or covered.
- Do not place a water containing vessel on this apparatus, as this can result in a risk of fire or electric shock. Do not expose this apparatus to rain or place it near water.
- If this apparatus accidentally gets wet, unplug it and contact an authorised dealer immediately.
- You can clean this apparatus with a damp cloth when necessary, but be sure to unplug the apparatus first. To cut off the power source, unplug the apparatus from the AC wall outlet.
- Do not overload AC wall outlets, power cables or adaptors beyond their capacity as this can result in fire or electric shock.
- Power cables should be routed so that they are not likely to be walked on or pinched by items placed upon or against them, paying particular attention to cables at the plug end, adaptors and the point they exit from the appliance.
- Before connecting the AC power cable to the Speed Control Unit, make sure the voltage of the Power Unit, as marked on the identification label at the rear, corresponds to the local electricity supply.
- Never insert anything metallic into the open parts of this apparatus.
- Only a qualified technician should remove the Speed Control Unit cover.
- Be sure to hold the plug, not the power cable, when disconnecting this apparatus from an electric socket.
- Locate this apparatus near an easily accessible AC outlet.
- If this apparatus does not operate normally, in particular if there are any unusual sounds or smells, unplug it immediately and consult an authorised dealer.
- Unplug this apparatus from the AC outlet before any service.

IMPORTANT NOTICE:

The power cable on this equipment when supplied for use in the UK, is fitted with a moulded plug incorporating a fuse. The value of the fuse is indicated on the pin face of the plug and if it required replacing a fuse approved to BSI 1362 of the same rating must be used. Never use the plug with the fuse cover omitted if the cover is detachable. If the plug fitted is not suitable for the power points in your room or if the power cable is not long enough to reach the power point, you should obtain a suitable safety approved extension lead or consult your dealer for assistance.

IMPORTANT:

The wires in the power cable are coloured in accordance with the following code: BLUE NEUTRAL, BROWN LIVE. As these colours may not correspond to the coloured markings identifying the terminals in your plug, proceed as follows: The wire coloured BLUE must be connected to the terminal marked with the letter N or coloured BLUE or BLACK. The wire coloured BROWN must be connected to the terminal marked with the letter L or coloured BROWN or RED.

WARNING:

DO NOT CONNECT EITHER WIRE TO THE EARTH TERMINAL, WHICH IS MARKED WITH THE LETTER (E) OR BY THE EARTH SYMBOL OR COLOURED GREEN OR GREEN/YELLOW.

**WEEE SYMBOL INFORMATION**

Correct Disposal of This Product (Waste Electrical & Electronic Equipment)

(Applicable to the European Union and other European countries with separate collection system).

The marking shown on this product or its literature, indicates that it should not be disposed with other household wastes at the end of its working life. To prevent possible damage to the environment or human health from uncontrolled waste disposal, please separate this from other types of wastes and recycle it responsibly to promote the sustainable re-use of material resources.

Household users should contact either the retailer where they purchased this product or their local government office, for more detailed information of where and how they can take this item for environmentally safe recycling.

Business users should contact their supplier and check the terms and conditions of the purchase contract.

This product should not be mixed with other commercial wastes for disposal.

Introduction

SME is an iconic brand founded in 1946 by audio legend Alastair Robertson-Aikman in West Sussex, England. Today SME is recognised as makers of the finest precision turntables and tonearms in the world. Entirely made in-house by state of the art manufacturing processes, complemented by traditional craftsmanship methods. SME audio has evolved from 75 years of engineering excellence, innovation and perfection delivering precise and pure audio reproduction.

The Model 6 is a precision turntable with a CNC machined chassis made from a unique polymer high density resin material which provides high mass and superb resonance absorption. The chassis is complemented by a specialist isolation system incorporated into the self-levelling feet. The main bearing, spindle and drive pulleys are precision made to the same exact standards as all SME high-end turntables. Speed control is a highly sophisticated bi phase, frequency and amplitude, DSP based sine wave generator, with a dedicated discrete power amplifier to drive the motor. It generates two pure sine waves which drive twin coils present inside a custom made AC motor. The frequency (speed) is user adjustable in approximately 0.0133 Hz steps allowing a very accurate musical pitch to be set.

The Model 6 is equipped with the highly credible SME M2-9 tonearm which is of meticulous build quality. Primary features include lightweight stainless steel tonearm tube, detachable aluminium headshell with double draw pins for extra rigidity and azimuth adjustment, thumbwheel vertical tracking adjustment, tungsten balance weight(s) and high quality ball race bearings in all planes. The M2-9 tonearm is designed to suit a wide range of cartridges up to 38 grams and with a direct plug-in head up to 46 grams.

Design and engineering excellence built by audio enthusiasts for audio enthusiasts.

Contents

| | |
|----|---------------------------|
| 1 | Weights & Dimensions |
| 2 | Packing List |
| 3 | Parts Identification |
| 4 | Unpacking |
| 5 | Setting Up |
| 6 | Operation – Speed Control |
| 7 | Operation – Turntable |
| 8 | Tonearm |
| 9 | Maintenance |
| 10 | Transit Precautions |
| 11 | Guarantee |

1. Weights & Dimensions (mm)

Turntable

Width: 420

Depth: 320

Height: 128

Platter Diameter: 300

Spindle to Arm: 215.4

Net Weight: 9.1kg

Speed Control Unit

Width: 220

Depth: 200

Height: 85

Net Weight: 2.05kg

2. Packing List

| Qty | Description | ✓ |
|-----|--|--------------------------|
| 1 | Packing List for Model 6 | <input type="checkbox"/> |
| 1 | Model 6 Serial No | <input type="checkbox"/> |
| 1 | M2-9 Tonearm | <input type="checkbox"/> |
| 1 | Control Unit – 100V <input type="checkbox"/> 115V <input type="checkbox"/> 230V <input type="checkbox"/> | <input type="checkbox"/> |
| 1 | Power Cable – UK <input type="checkbox"/> EU <input type="checkbox"/> USA <input type="checkbox"/> | <input type="checkbox"/> |
| 1 | Platter | <input type="checkbox"/> |
| 1 | Stroboscopic Disc | <input type="checkbox"/> |
| 1 | Record Clamp | <input type="checkbox"/> |
| 1 | Spindle Washer | <input type="checkbox"/> |
| 1 | Drive Belt | <input type="checkbox"/> |
| 1 | Velcro Strap | <input type="checkbox"/> |
| 1 | Balance Weight | <input type="checkbox"/> |
| 1 | Accessory Weight | <input type="checkbox"/> |
| 1 | Detachable Headshell | <input type="checkbox"/> |
| 1 | Finger Lift & Washers | <input type="checkbox"/> |
| 1 | Cartridge Screw Set | <input type="checkbox"/> |
| 1 | Bias Weight | <input type="checkbox"/> |
| 1 | Bias Guide | <input type="checkbox"/> |
| 1 | 2mm Hex Wrench | <input type="checkbox"/> |
| 1 | 0.89mm Hex Wrench | <input type="checkbox"/> |
| 1 | Alignment Protractor | <input type="checkbox"/> |
| 1 | Owner's Manual | <input type="checkbox"/> |

3. Parts Identification



1. Speed Control Unit
2. Power ON/OFF Button
3. Rotary Speed Control
4. Platter
5. Bias Weight
6. Bias Guide
7. Anti-Skate Lever
8. Balance Weight
9. Tonearm
10. Finger Lift
11. Headshell

Power Cable & Phono Connectors Identification



4. Unpacking

1. Unpack and check all items against the packing list in Section 2. In the very unlikely event that anything is missing your dealer should be notified at once.
2. The design of the turntable allows it to be used on any substantial table or similar piece of furniture in the absence of a dedicated audio equipment stand.

5. Setting Up

1. With the turntable sited, follow the set up instructions in the order detailed.
2. Drive belt installation: place the belt over the driven pulley, pressing it down as far as the lower flange and ensuring free from twists and stretch the belt over the motor pulley. Rotate the driven pulley slowly by hand to position the belt on the pulleys.
3. Platter fitment: ensure the upper face of the driven pulley and the underside of the platter mating surfaces are clean, place the platter squarely over the turntable spindle lowering it gently until it rests on the driven pulley.

4. Speed control unit: fit the mains power cable (check carefully that this matches your mains power voltage). The mains voltage setting is indicated on the back panel.

WARNING! To meet international safety standards the control unit is earthed through the yellow/green wire of the power cable and particular care must be taken to ensure that this is connected in order to maintain effective earthing.

5. Low voltage connection cable: connect the speed control unit to the turntable by inserting the cable plug into the 24v input socket at the rear of the turntable.

6. Operation – Speed Control

The Model 6 precision turntable is extensively run-in and it's speeds set before leaving the factory. If you should wish to check the speed settings and make your own adjustments, the procedure is as follows:

1. **Mains Power:** the power ON/OFF button is located on the rear of the speed control (power unit). With power ON the last used speed indicator LED light will illuminate on the speed control unit fascia.
2. **Motor Power:** pressing the power button on the speed control unit fascia will start the motor. With power OFF and pressing the rotary button on the fascia the speed settings of 33 and 45rpm will cycle and be indicated by the speed LED. With the motor running, pressing the power button will stop the motor.
3. **Speed Testing:** the stroboscopic disc installed on the platter is used to check speeds of 33 and 45rpm. Use the strobe bands appropriate for your mains AC frequency. The disc should be viewed in a fluorescent or neon light. The appropriate band will synchronise and

appear stationary when the speed is correct. Whilst forward and reverse band movement will indicate fast or slow running respectively. This is best observed with the cartridge fitted and the tonearm in the raised position and placed directly over the band being viewed as a reference point.

4. **Speed Adjustment:** with the motor running press and hold the rotary button for two seconds, the speed indicator LED will begin to flash. The motor is now in speed adjust mode and the speed can now be adjusted in conjunction with the stroboscopic disc. Turning the rotary button anti-clockwise will reduce speed and clockwise will increase speed. The method provides a microfine incremental adjustment. When the speed adjustment is completed depress and release the rotary button, the speed indicator LED light will stop flashing and become constant and the speed setting will be stored in the system memory for future use.
5. Repeat this process for the 45rpm speed range if required.

6. **Timeout:** if in adjustment mode and no adjustments have been made for 20 seconds the new settings will be saved and the system will exit adjust mode and resume running normally.
7. **Cancel/Abort Adjustment:** with the motor running and the system in adjustment mode, if the power button is pressed, the motor will stop and any adjustments that have been made will be discarded and not saved.

7. Operation – Turntable

1. Turn on mains power at rear of the speed control unit (push ON/OFF switch).
2. Place record spindle washer on spindle followed by the record.
3. Fit record clamp by holding main body of the clamp and turn locking knob gently about 1/4 turn.
4. Select required speed by pressing the rotary control button on speed control unit until 33 or 45 is indicated.
5. Press power button.
6. You are now ready to play your record.

8. Tonearm

- General Arrangements
- Dimensions
- Specifications
- Fitting Balance & Bias Weights
- Fitting Headshell & Cartridge
- Tonearm Set Up & Adjustment

Note:

Tonearm images for references only, mounting base plate profile may vary.

For your convenience the headshell is supplied detached from the tonearm ready for fitment of your cartridge.

Cartridge not supplied – images of cartridge used for illustration purposes only.

General Arrangement

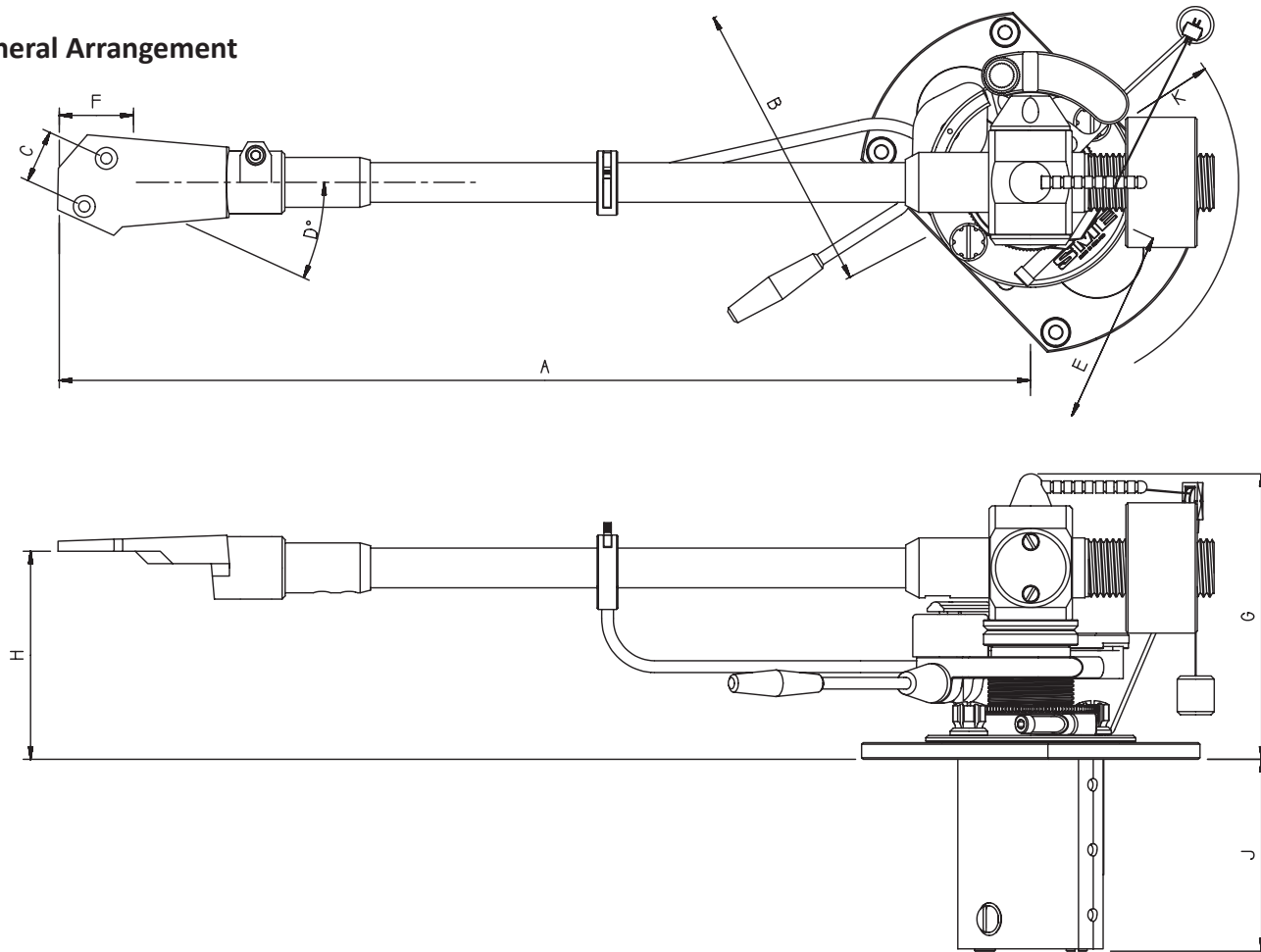

| Dimensions | (mm) |
|--|--------|
| A – Pivot to Stylus | 233.20 |
| B – Pivot to Turntable Centre | 215.40 |
| C – Cartridge Fixing Centres | 12.70 |
| D – Offset Angle (degree) | 23.630 |
| E – Linear Offset | 93.47 |
| F – Overhang | 17.80 |
| G – Height above Mounting Surface (Max) | 87.00 |
| G – Height above Mounting Surface (Min) | 63.00 |
| H – Mounting Surface to Underside of Headshell (Max) | 67.40 |
| H – Mounting Surface to Underside of Headshell (Min) | 43.40 |
| I – Depth below Mounting Surface | 46.00 |
| J – Balance Weight Clearance Radius | 51.00 |

| Specifications | (g/mm) |
|------------------------------------|--------|
| Effective Mass (g) | 9.50 |
| Cartridge Balance Range (g) | 5-12 |
| Vertical Tracking Force (g) | 0-2.5 |
| Maximum Tracking Error (degree/mm) | 0.013 |
| Null Point: Inner (mm radius) | 66.04 |
| Outer (mm radius) | 120.90 |
| Silver Litz Internal Wiring | |

Fitting Balance & Bias Weights

The tonearm balance and bias weights are packed separately for safety in transit. Carefully screw the balance weight onto the threaded stud on the rear of the tonearm, the dial should face forward towards the headshell.

Fitting of the bias weight is described in the following set up pages.

Fitting Headshell & Cartridge

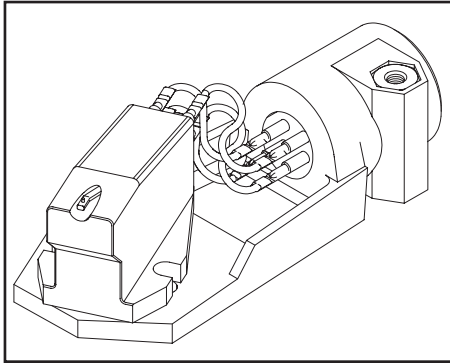

Before fitting the cartridge see that the stylus guard (not illustrated) is in position as a precaution against accidental damage.

The cartridge leads have $\varnothing 1.2\text{mm}$ receptacles to suit the cartridge.

The coding is as follows:

| | | |
|-------|---|----------------------|
| Red | – | Right Channel Signal |
| Green | – | Right Channel Ground |
| White | – | Left Channel Signal |
| Blue | – | Left Channel Ground |

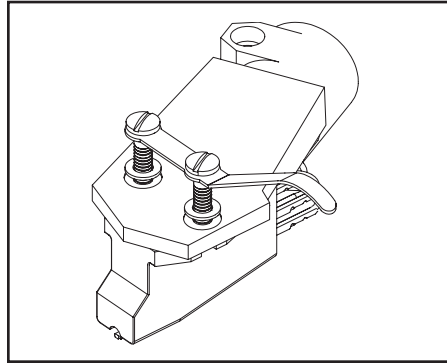

Most cartridges have their own screws. One pair #3-48 UNC x 11mm with nuts and washers are provided.

For the purist, use without the finger lift is preferred but is unlikely that any difference will be audible. When used the two stainless steel washers should first be fitted to the counterbores in the headshell.

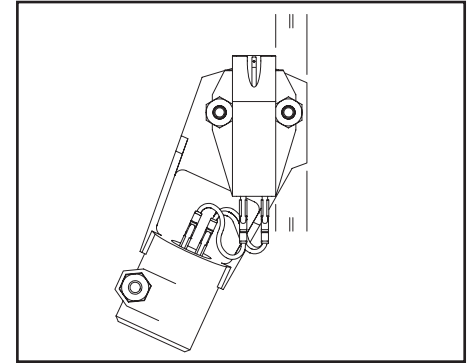

Examine the top of the cartridge. It is important that it presents a good flat face to the underside of the headshell. Before final tightening check that the cartridge is lying parallel to the reference edge of the headshell.

Tighten the fixing screws securely using a screwdriver, which must be a good fit in the screw slots to avoid damage. Hold the nut if necessary to prevent rotation.

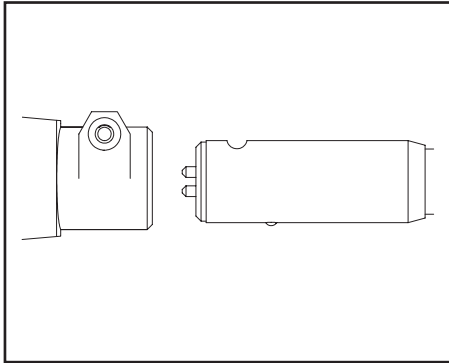

Using the 2mm wrench release the headshell clamp bolt and remove it. The nut remains in its housing in the underside of the headshell where it is retained with adhesive.

Offer up the headshell to the tonearm identifying the half-round keyway near the front.

As the headshell is pushed onto the tonearm, resistance will be felt as the spring loaded contact pins in the tonearm plug are compressed.

Align the bolt hole in the headshell with the keyway in the tonearm and insert the clamp bolt until it contacts the nut. Tighten lightly using the 2mm wrench.

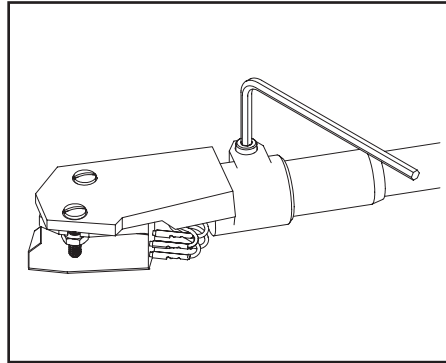

Using the 2mm wrench release the clamp bolt and unscrew it. To remove the bolt push the headshell onto the tonearm using just enough pressure to overcome the spring-loaded contact pins in the tonearm plug. The clamp bolt should then be loose enough to lift out using the long leg of the wrench whilst applying slight tilt so that it does not slip out of the socket.

Tonearm Set Up & Adjustment

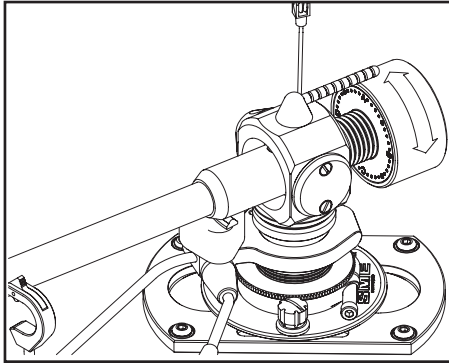

Position the tonearm so that it is clear of the armrest and the cartridge is clear of the turntable. Move the control lever into the lowered position. Balance the tonearm by rotating the weight to move it backwards or forwards as required.

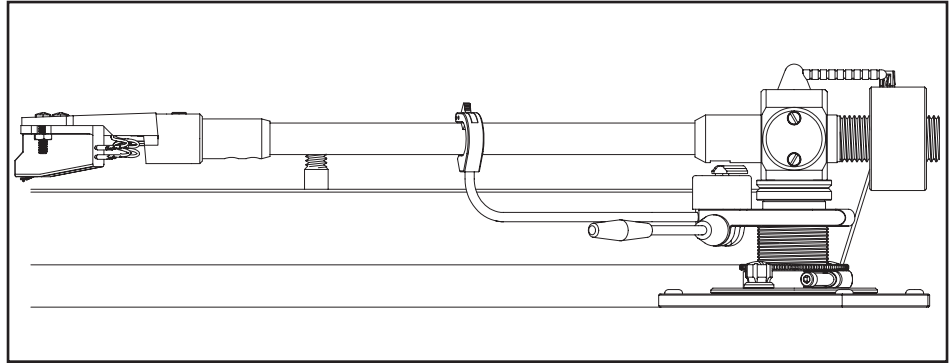

Adjust until the tonearm (with the cartridge fitted) is either level or slightly low at the front end.

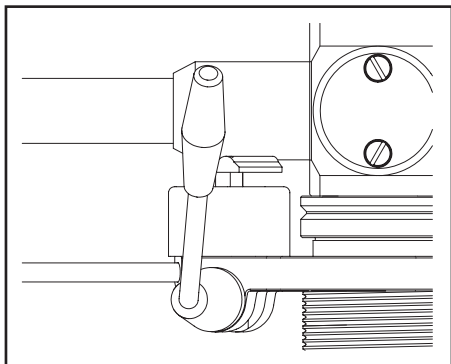

For safety the lever of the lowering control should now be moved into the raised position.

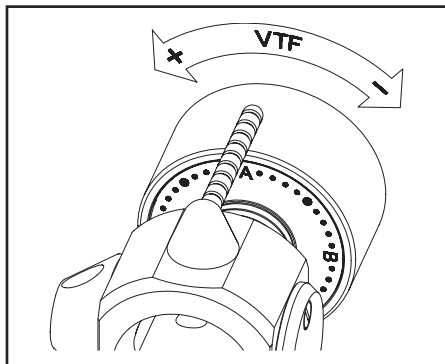

VTF is set after longitudinal balancing has been completed.

It is applied by rotating the weight, anti-clockwise to increase and clockwise to decrease.

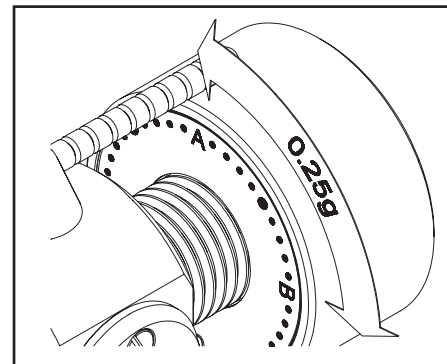

The indicator on the front face of the weight carries the letters A-B-C-D at quarter turn intervals.

Note the position of one of the letters and rotate the weight anti-clockwise. One full turn for 1.0g and 0.25g for each letter. For example for 1.5g one and half turns will be required.

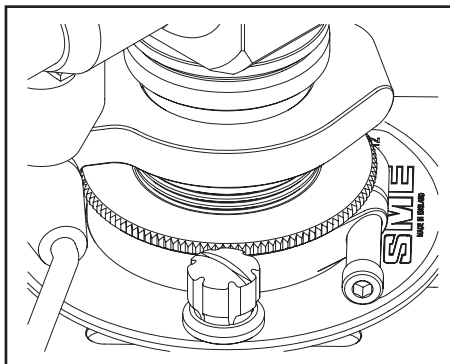

Release the pillar clamp screw using the 2mm wrench, by one turn only.

Rotate the VTA thumbwheel clockwise to increase the height of the tonearm relative to the base.

To lower the tonearm turn the VTA thumbwheel anti-clockwise. Finger pressure may be required to move the arm downwards until it stops on the tonearm base, at which point further movement in either direction can be made as necessary.

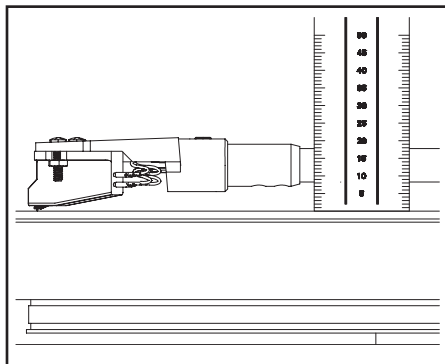

Use an old but un-warped record for the following procedures in case of accidental damage.

Place the tonearm about halfway across the record and move the control lever forward to lower it into the playing position.

As the top of the cartridge is normally its horizontal datum, correctly fitted it will be parallel with the tonearm. The alignment protractor has also been designed to act as a height gauge. Measure the distance from the surface or the record to the top of the tonearm tube at the front of the arm using the left-hand scale.

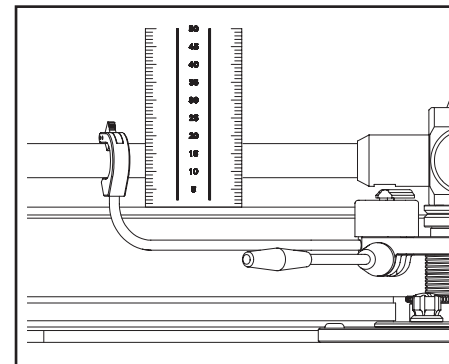

Re-position the alignment protractor about 6mm from the edge of the record. Using the right-hand scale repeat the measurement and compare it with the first one. Adjust with the VTA thumbwheel until similar readings are obtained indicating that the tonearm is level with the surface of the record. Re-lock the pillar clamp screw. View the tonearm in the playing position and re-adjust as necessary.

Other settings can be noted and used for special needs.

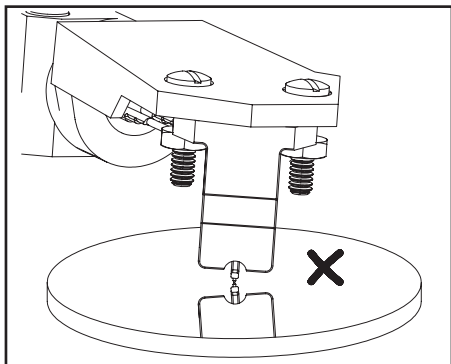

Place a small mirror on the turntable and rest the stylus on it. Viewed in this way any departure from the vertical is accentuated and easily visible.

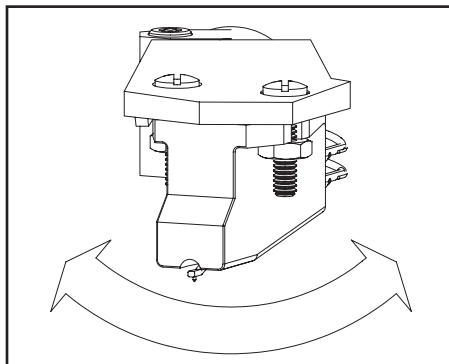

Release the headshell clamp bolt by one quarter turn. The stylus must be clear of the mirror whilst this is done.

Holding the headshell close to the tonearm, rotate it in the required direction. The clamp bolt allows enough movement for this adjustment.

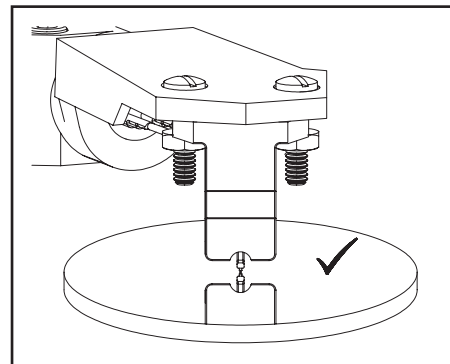

Re-check with the mirror and when satisfied tighten the headshell clamp bolt firmly with the 2mm wrench, avoiding excessive force.

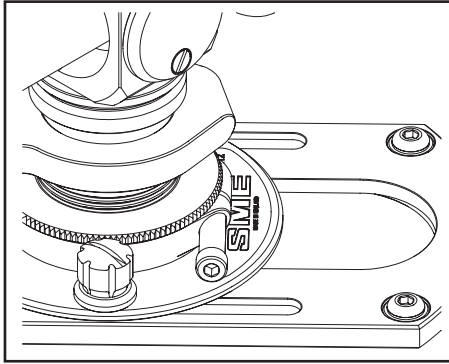

Place the tonearm into the armrest and release the two base clamp nuts, using a snugly fitting screwdriver.

Move the base on the bedplate as far forward as it will go.

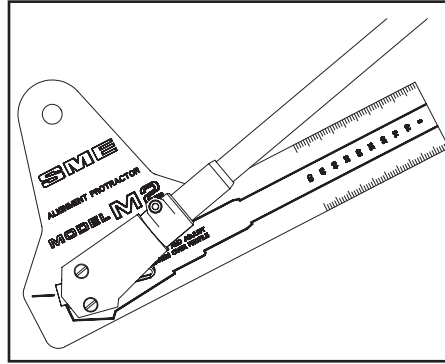

With a record on the turntable, place the alignment protractor onto the record spindle. Check that the VTF has been set to suit the cartridge in use. A small cross indicates the stylus position on the protractor. Move the tonearm out of the armrest and place it so that the stylus enters the indent formed at the centre of the small cross.

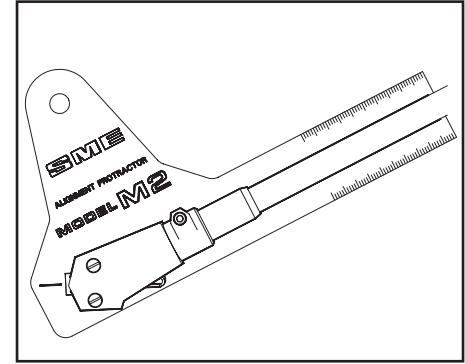

Most cartridges have a stylus-fixing hole dimension of 9.5mm. With these, the outlines of the tonearm and protractor will coincide when viewed directly from above the centreline of the tonearm. With others according to the position of the stylus, it will be necessary to view slightly to the left or right of the centreline; the only requirement for the correct HTA being that the outlines appear to coincide as shown.

Replace the tonearm in the armrest and remove the protractor.

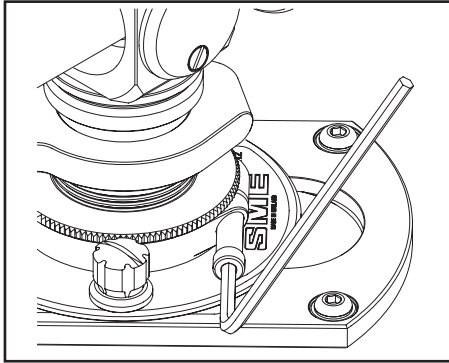

Release the pillar clamp screw using the 2mm wrench.

Height adjustment will be maintained by the VTA thumbwheel.

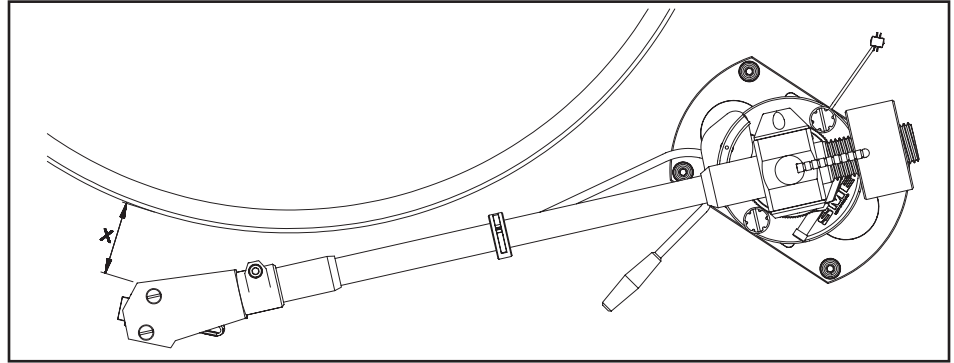

Rotate the pillar to position the armrest conveniently in relation to the turntable. The dimension 'X' should not be more than 75mm or less than 25mm.

Tighten the pillar clamp screw firmly, avoiding excessive force.

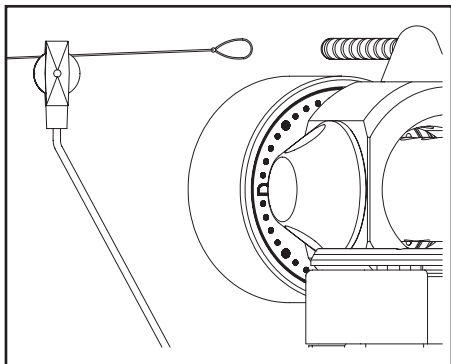

Thread the cord through the guide pulley housing and pass the loop over the anti-skate lever.

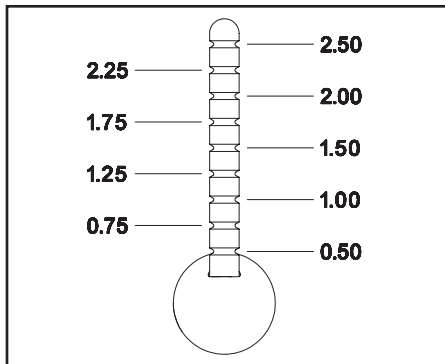

Drop the loop into the groove corresponding to the vertical tracking force being used.

Anti-skate is always a matter of compromise. The values indicated are a good starting point. Note how the stylus enters the run-in groove. 'Snatch' would indicate the need for a lower value.

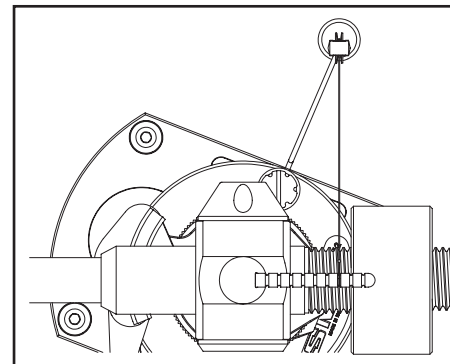

Loosen the inner base clamp nut enough to allow movement of the anti-skate guide. Position the guide so that the cord is approximately 90° to the anti-skate lever when the stylus is over the outer groove of a twelve inch record. Firmly re-lock the base clamp nut. Rotate the guide pulley housing to align it with the cord, which must lie in the groove of the pulley.

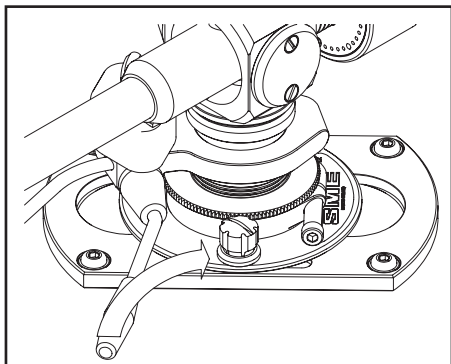

Rotate the control lever fully, in the direction of the arrow, and move the tonearm out from the armrest.

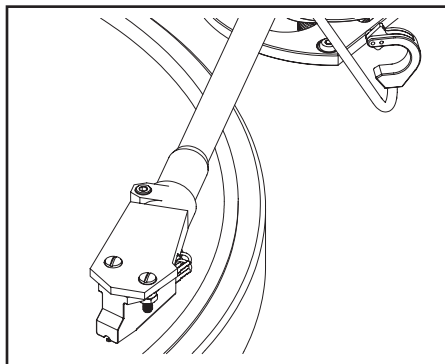

Position the tonearm so that the stylus is over the selected track of the record.

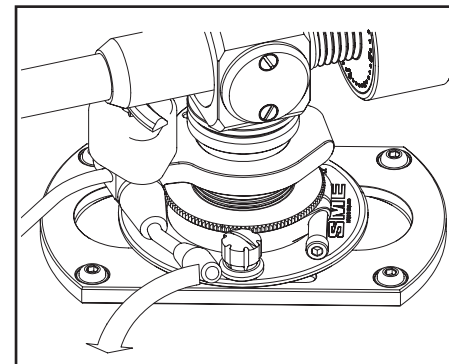

To lower the stylus onto the record move the control lever forwards, in the direction of the arrow, just past top dead centre. This will set the control in motion, at which point it will take over the movement of the lever, giving a smooth controlled descent.

Note: For the correct descent times the control must be operated exactly as above. The descent speed will increase considerably if the lever is pushed down instead of being allowed to fall of its own accord.

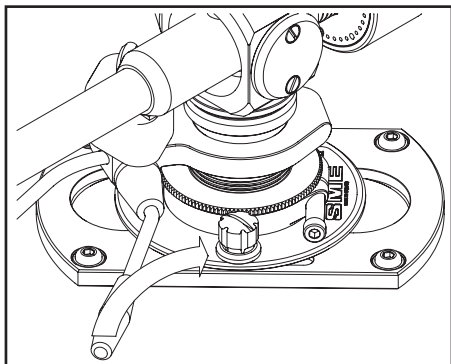

To raise the stylus from the record move the control lever back to its original position. When the tonearm is not in use it should always be returned to the armrest for safety.

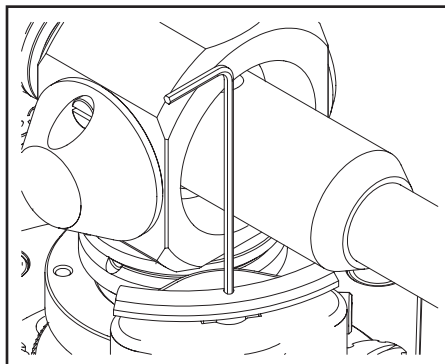

The raising and lowering control is set to suit the majority of cartridges but the height raised above the record can be changed to meet individual needs.

The small hole in the centre of the arm lift provides access to the adjustment screw. Insert the long leg of the 0.89mm wrench through this hole to engage the screw. Clockwise rotation will decrease the height of the lift: anti-clockwise rotation will increase height.

The adjustment is sensitive so the wrench should only be turned a few degrees at a time. Apply firm downward pressure to the arm lift after each clockwise rotation of the adjustment screw.

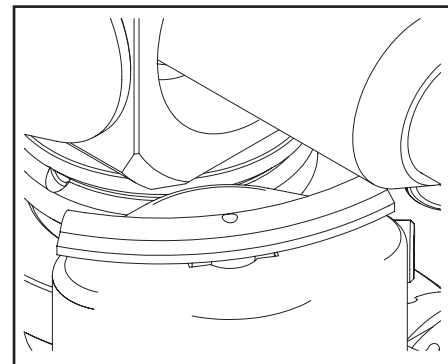

If the tonearm drifts outwards during raising or lowering it indicates contaminant on the rubber pad. To restore positive working, wipe the pad with a damp cloth and repeat with a paper tissue until dry. Clean the underside of the tonearm in the same manner where it contacts the rubber pad.

9. Maintenance – Turntable

1. There are no critical adjustments or need for ‘tweak’ and only very little maintenance. Clean the drive belt occasionally by drawing it through a piece of soft linen moistened with lighter fuel. The same material may be used to clean the periphery of the motor and driven pulleys.
2. Replace the drive belt after 1000 hours or two years.
3. Clean the turntable only with a microfibre or lint free clean cloth, lightly dampened with luke warm water and if necessary one drop of washing up liquid.
4. There are no user-serviceable parts inside the turntable or speed control unit.

10. Transit Precautions

The Model 6 can be safely transported

SUBJECT ABSOLUTELY TO THE FOLLOWING PRECAUTIONS:

Short journeys by car: remove the platter, disengage the drive belt from the motor pulley. Secure the tonearm in the arm rest using the velcro strap supplied, fit cartridge guard or remove headshell with cartridge fitted. The turntable itself is best placed on the floor of the car in front of the passenger seat. The platter and other items can be stowed elsewhere provided they are carefully protected. However, for anything other than a short journey it is recommended that the turntable is packed in its original packing box for transportation purposes.

11. Guarantee

Your SME Model 6 turntable is guaranteed against faulty material and workmanship. The nominal period of the guarantee is 24 months but is liberally interpreted at SME's discretion subject to the following conditions being observed:

1. Any matter arising must in the first instance be reported to SME Limited at the address appearing below.
2. Do not return the turntable or any part thereof to SME Limited unless requested to do so.
3. SME Limited will not accept liability for any items until they reach the factory safely.
4. Any parts found to be faulty will be replaced free of charge.
5. Return transport and insurance costs will be charged.
6. The guarantee expressly excludes:
 - a. Damage by any cause.
 - b. Contingent and third party liability.
 - c. Personal injury.
7. No alteration or variation of the guarantee will be recognised by SME Limited.
8. The guarantee is not transferable.

SME LIMITED • MILL ROAD • STEYNING • WEST SUSSEX • BN44 3GY • ENGLAND
T: +44 (0) 1903 814321 • E: service@sme.ltd.uk • W: www.sme.ltd.uk

Appendix

We hope these instructions have made the set up of your Model 6 precision turntable and tonearm straightforward. Care for it will befit its fine construction. Do not invert it except where directed for service. Do not attempt to take it to pieces or interfere with any of the assembly screws except as directed in the instructions. To do so will invalidate the guarantee and may incur costly repairs. Fit the cartridge stylus guard in place carefully when not in use, to reduce the possible risk of damage. Keep your turntable clean by dusting it regularly with due regard for the safety of the cartridge and stylus.

In the unlikely event of a problem concerning operation or service, always contact SME Limited in the first instance at the address at the bottom of Section 11 (Guarantee), stating the exact nature of the problem, the name and address of the dealer who supplied the unit and its serial number which will be found on the label at the rear of the turntable base.

EC DECLARATION OF CONFORMITY

The SME Model 6 turntable has been manufactured to conform with the protection requirements of the EC Council Directive 89/336/EEC relating to EMC by application of the following standards:

BS EN 61000-6-3:2007 + A1:2001 Emissions Standard & BS EN 61000-6-1:2007 Immunity Standard.

Also the requirements of the EC Low Voltage Directive relating to electrical safety by application of the following standard:

BS EN 62368-1:2014 International Safety Standard.

For the purposes of testing the SME Model 6 turntable was used with the high quality interconnects supplied by SME Limited. Compliance with the above standards may only be made if the unit is installed as per this manual and using the correct cables.

SME Limited · Mill Road · Steyning · West Sussex · BN44 3GY · England

SME

SME LIMITED • STEYNING • WEST SUSSEX • ENGLAND