



Loving music

THE HEART OF MUSIC



Contents

Vision and Values	04 – 05
Turntables	08 – 33
Tonearms	36 – 47
Cartridges	50 – 57
Electronics	60 – 75
Record Cleaning	76 – 81
Accessories	84 – 95
Company	96 – 101
Technical Specifications	104 – 115
Imprint	117

... for the love of music

Perfect composition of precisely coordinated components results in excellent performance, audiophile authenticity, and leading edge quality.

If everyone achieves their best and contributes to the overall picture, then new superlatives become possible. This is what connects and pushes us every day.

After more than 45 years, the Clearaudio brand continues its history, operated as a family business. Our management duo of siblings share their love of music, enthusiasm for the steadily growing vinyl community, and the passion for our high-end manufacture in Erlangen, located at the center of research and technology.

Together with our fantastic team, we are responsible for what electrifies this community and makes them listen up: Music reproduction from vinyl records that, thanks to its realism, involves us like a live concert. All positions within our team are mastered through talent and experience – always committed to the company philosophy:

“Take the best, make it better -
Only then it is just good enough.”

For this reason, Clearaudio can consistently optimize the real-life musical experience to fulfil what our customers expect. And we feel obliged to meet those expectations.

We have respected this belief since we founded our manufacture in 1978, the year our first moving coil cartridge was developed and patented. From that point on, we have continuously improved our premium models, utilizing our in-house specialists to make an audiophile sound for everyone. Our concept series is most extraordinary and best sounding for young vinyl fans and their budgets. The options for improvement remain, for example, by choosing a higher quality cartridge or specialized power supply.

Another creed we put into action: It doesn't matter what style of music touches you. Clearaudio technical always signifies the pure enjoyment of a life performance and a solid investment for generations to come.

At Clearaudio we embrace analog audiophilia as a whole, with first-class turntables, tonearms and phono cartridges. We pay particular attention to the choice of materials, from polished diamonds on boron needle carriers to micro-wire gold coils, ceramics, and armoured “panzerholz” wood. In addition, our selection extends from excellent pre-amplifiers to a wide range of accessories, including record cleaning machines, plus plugs and cables, for extended listening pleasure. Our Clearaudio music division, includes new releases, re-issues, and our own analogue recordings on vinyl, completing the portfolio of our family business.

It is about loving music. The vinyl market, once believed dead, continuously increases in yearly growth. Our company Clearaudio inspires both music lovers and technology fans around the world in more than 80 countries. They are seeking live sound quality, raising the bar a little higher with every innovation.

Everything literally results in “hearing sense” – music coming alive with breath-taking designs that prove that acoustic masterpieces go hand in hand with aesthetic craftsmanship.

Electrify the music you love: Experiencing it in your home as from the best seat at a live concert.



Veronika Suchy, Robert Suchy (f.l.t.r.)

Emotion – Live



Statement V2

Take the best and make it better, only then it is just good enough. Based on this philosophy, Clearaudio has been setting new standards in analogue music reproduction for more than 45 years. Based on their shared love for music, the Suchy family have designed an exceptional new turntable that breaks the rules and boundaries of music reproduction. The results of their tireless passion and commitment are the outstanding Statement V2 turntable and the Statement TT1 tangential tonearm, designed to reproduce music from vinyl records at the highest possible level.

The Statement V2 turntable combines unprecedented functionality, beautiful design and superb engineering with innovative patented Clearaudio technology.

This fusion of extraordinary craftsmanship, attention to the smallest details and elaborate state-of-the-art production reflects the creative values of the Suchy family and their on-going passion to build innovative turntables at the highest level that are inspiring and set new standards of performance.

Even the most minute musical details are faithfully reproduced. Nothing is added, coloured, distorted or lost. Let your ears relax as they hear only the music, the whole and complete musical performance.

Discover another dimension of music reproduction.



Statement V2



Statement TT1



They call it the pinnacle of analogue music reproduction: The patented Statement TT1 tangential tonearm developed by Clearaudio has been copied many times, but never matched. As its name implies, the TT1 represents the ultimate statement in tangential tonearm construction. This pinnacle of tangential tonearm technology is a key yardstick for Clearaudio's development team. With the Statement TT1, records are replayed as they were cut – in a straight movement with no curves. Hence the cartridge's stylus tracks the record groove perfectly without errors. In addition, Clearaudio uses a unique

passive technology: A self-sufficient tonearm drive with a purified mechanical design was created to combine optimal resonance values with maximum freedom from interference in the transmission of the music signal. In the TT series, Clearaudio uses accurately crafted high-quality materials that are subject to ongoing quality control. Stability and value come first. Uncompromising consistency and ongoing innovation and development make Clearaudio a pacesetter in tangential tonearm technology, always moving towards the perfect audiophile listening experience.



Patented non-contact magnetic drive



Precise arm height adjustment allowing fine tuning of VTA, even during playback



Self-levelling mechanism with massive stainless steel pendulum

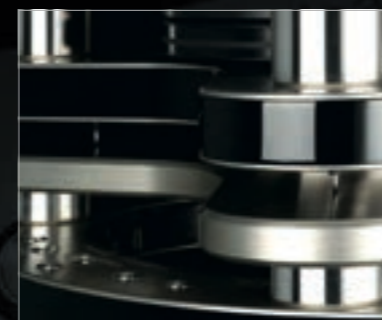

Damped, floating main chassis

Turntable technology at its finest

The goal of high-end analogue is to perfectly merge technology, workmanship and design and subordinate them to one single target: The best possible music reproduction. At Clearaudio, all development, design and production remain firmly in the hands of a perfectly experienced and attuned team of specialists who never lose sight of that goal, and who uphold the Clearaudio philosophy and high-quality standards.

From the tiniest part to the full audiophile 'Gesamtkunstwerk' (a complete work of art that draws on many art forms), at Clearaudio everything is meticulously made by hand – with maximum precision and plenty of passion. Precision-crafted mechanics and the use of components fine-tuned for density, mass and shape guarantee mechanical harmony and the absence of resonance when playing records. The ingredients are high-density bullet proof wood, titanium, stainless steel V2A, aluminium and specially developed high-performance plastics. Two parameters are of critical importance: Maximum performance of music playback and technically effective design, as well as the aesthetic beauty of our creations.



Master Innovation - Masterfully optimised

The biggest model in the popular Innovation series shows clearly how even the best is constantly being further developed and brought to new sonic heights at Clearaudio. The 70mm thick, dynamically balanced platter made of resonance damping plastic with a 15mm thick precision-machined stainless steel sub-platter delivers the highest mechanical standards. The Master Innovation doubles the inertia of the Innovation. Incredible rotational speed stability is achieved thanks to the combination of the patented Clearaudio ceramic magnetic bearing (CMB) supplemented by an additional flywheel and a high-torque DC motor.

An infrared sensor sends signals to an optical speed control mechanism to consistently maintain the perfect speed, while non-contact magnetic decoupling of the drive prevents any motor system vibration or noise from reaching the main turntable. Consequently, speed variations are eradicated and perfect pitch is obtained.

The Master Innovation provides the ability to mount up to three tonearms. Existing Innovation owners have the option to upgrade to Master Innovation level.



Master Innovation,
black with TT1 MI tonearm



Speed selection and motor control



Possibility to install up to three tonearms, picture shows Clearaudio TT2 tangential tonearm

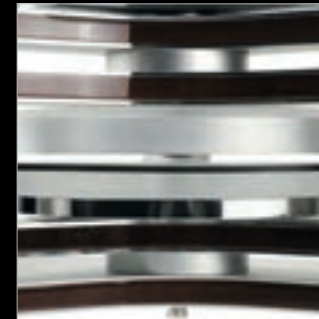

Contactless drive through magnetic platter



Possibility to install up to three tonearms, picture shows Clearaudio Universal radial tonearm



Master Innovation,
wood with
TT1 MI tonearm



Master Innovation,
wood with
TT2 tonearm

Innovation - Perfect synchronisation

In the world of turntable construction the Innovation is the ultimate technological prototype. An infrared sensor combined with Clearaudio's optical speed control (OSC) ensures an outstanding level of speed stability – a prerequisite for optimal listening. A high-torque decoupled DC motor effortlessly rotates the precision-machined 70mm thick platter made of high-density acrylic.

The platter rotates in a virtually friction-free environment atop the 15mm thick stainless steel sub-platter, thanks to Clearaudio's patented ceramic magnetic bearing (CMB). A convenient choice of three rotational speeds is also at your fingertips, and it is possible to install a second tonearm.



Detail of Clearaudio Universal tonearm



Clearaudio da Vinci V2 MC cartridge



Innovation, black with TT3 tonearm



Innovation, wood with Universal tonearm



Speed selection and motor control

Detail of CMB drive unit



Music live

Innovation Compact - Efficient by design

Perfectly matched materials meet patented Clearaudio technology. The 70mm thick platter of the Innovation Compact consists of dynamically balanced polyoxymethylene (POM) and is powered by a high-torque DC motor with precision bearings, developed exclusively for Clearaudio. The Innovation Compact turntable with its very efficient design is nothing less than an audiophile revelation. Thanks to optical speed control (OSC),

speed stability values are obtained that lift this turntable into the global high-end class. The optimally designed chassis keeps resonances out of the audible range and guarantees maximum stability in a housing made of a massive bullet proof wood and aluminium sandwich. Timeless design with quality built to last for decades. The option to mount a second tonearm makes it possible to play a rich variety of music from across the decades.



Innovation Compact, black with Tracer tonearm

Innovation Compact, wood with Tracer tonearm



Motor unit with speed selection



Turntable height adjustment and alignment



The rear of the turntable, showing the external power supply input

Innovation Basic – Ticket to the top of the world

With the Innovation Basic turntable, you step into the next class of high-end technology from Clearaudio. This model benefits from the advanced design features of the Innovation turntable - but in a minimalist design.

The Innovation motor control (OSC = Optical Speed Control), developed by Clearaudio, ensures a constant speed of the turntable and allows a comfortable selection of individual speed levels. Combined with the patented Clearaudio ceramic magnetic bearing technology (CMB), the world's most accurate speed measurements are reached.

The horizontal position of the platter can be achieved by fine adjustment of the the height-adjustable turntable feet.

Technical details like the precision drilled 38mm polyoxymethylene (POM) platter and an exclusively DC motor are the seminal quality features of the Innovation Basic turntable. Due to two solid armboards the installation of two tonearms is possible.

The Innovation Basic is also available in the sublime bullet proof wood version, the hardest wooden compound so far, in order to achieve music output in perfection.



Innovation Basic, black with TT5 tonearm and swing base

Innovation Basic, wood with Profiler tonearm



Detail of Clearaudio tangential tonearm TT5 and swing base



Turntable height adjustment and alignment



Clearaudio Satisfy Kardan radial tonearm

Ovation - Classical elegance

Within a precision-machined chassis comprising a sandwich of aluminium and bullet proof wood, 100,000 tiny metal balls eliminate any possibility of harmful resonances. Hidden under a 40mm thick platter made of resonance-damping polyoxymethylene (POM) is a very quiet decoupled DC motor with high-torque. The design of the Ovation seems both timeless and minimalist – maximum music enjoyment needs no embellishment.

With Clearaudio's optical speed control (OSC) and ceramic magnetic bearing (CMB), the Ovation achieves supreme speed stability and redefines the standards in its class.



Convenient speed control at the push of a button



Silver anodized aluminium surface



Magnetically floating aluminium precision sub-platter



Ovation,
black with Tracer tonearm



Ovation,
wood with Clarify tonearm

Performance DC - High-end for all

The Performance DC is a turntable designed to open up the high-end listening experience to those ambitious music lovers who are willing to handle the basic features of tonearm and cartridge adjustment, and who simply seek the best in music reproduction.

A newly developed DC motor with high-precision bearings and flat belt-drive, in conjunction with a platter of 40mm thick POM which rests on a Clearaudio ceramic magnetic bearing (CMB), provide optimal conditions for the correct sampling of the record groove.

Excellent tracking properties and hyper-accurate speed synchronisation ensure the ultimate listening pleasure, regardless which Performance DC package you choose. The wide range of Clearaudio tonearms and cartridges offers almost infinite combinations that leave nothing to be desired. Also the endless color combination of the Performance DC makes hearts beat faster.



Performance DC,
black / black with TT5 tonearm
and swing base



Performance DC,
rose gold / dark red wood
with Tracer tonearm



Performance DC,
silver / silver
with Clarify tonearm



Performance DC,
silver / black
with Clarify tonearm



Performance DC,
black / silver
with Clarify tonearm



Performance DC,
black / wood with Tracer tonearm



Performance DC,
silver / wood
with TT5 tonearm
and swing base



Magnetically floating aluminium
precision sub-platter



Detail of Clearaudio radial tonearm
headshell



Performance DC,
black / black with acrylic platter



Performance DC,
silver / white

concept *Signature*

Striving for perfection is one of the guiding principles at Clearaudio. All products from the high-end manufacturer in Erlangen embody this DNA. This includes the concept, which was introduced in 2009 and has since been very successful with over 20,000 units sold.

As an entry-level package, the concept already created a revolutionary sound package with an undisputed price, design, and performance ratio, featuring a specially developed tonearm and cartridge. After more than 10 years of consistency, the best gets even better, and the concept undergoes several updates under the new name concept Signature.



concept *Signature*

The fundamental idea behind concept Signature remains as purposeful and user-friendly as its predecessor, as all parameters of the individual components are already perfectly set at the factory.

The core of the turntable body is made of medium-density fiberboard or optionally, solid wood layers bonded under high pressure. The top layer of the turntable is made of specially satin-finished plastic. This composition minimizes resonances and ensures a perfect visual appearance.

The platter is driven by a polished flat belt from a completely decoupled direct current motor to minimize the transmission of interference noise.

The new control technology with integrated auto-calibration, new adjustment options, and additional Tacho-Speed-Control („TSC“) achieve even better measurements in terms of uniformity and impulse stability. The entirely newly developed Tacho-Speed-Control constantly monitors the speed and provides real-time feedback to the control electronics. This allows it to immediately respond to changing influences such as decreasing belt tension, friction of the platter bearing, or temperature fluctuations. Additionally, TSC performs an automatic calibration at every restart. With the new concept Signature, manual recalibration is also possible at the push of a button on the back of the turntable.

Several O-rings („IMS“) improve the motor suspension decoupled from the chassis, which is adopted in a modified form from the Reference Jubilee. Simultaneously, the new encoder forms the basis for even more features of future generations and expansion stages.

In terms of design, the concept Signature stands out. The redesigned surface with an illuminated touch controller allows for intuitive operation of the turntable and sets new design accents.

The wide selection of Clearaudio tonearms and cartridges leaves nothing to be desired in terms of modularity. Perfect combinations for the concept Signature turntable include all MM cartridges, all MC cartridges from concept mc to Talisman V2 Gold, as well as all tonearms from concept to Profiler. Additionally, the concept clamp, a specially designed acrylic cover, and the nano phono V2 / smart phono V2 phono preamplifier or one of the two upgrade power supplies, Professional Power 12V / smart power 12V, from Clearaudio are recommended.

The concept Signature will also be available in the four chassis colors: silver, black, wood and dark wood.



concept Signature,
black with concept tonearm



Clearaudio concept mc cartridge



Illuminated controller with touch function for intuitive operation.



concept Signature, back



Detailed picture of motor suspension and Tacho-Speed-Control



concept Signature,
dark wood with concept tonearm



concept Signature,
wood with concept tonearm



concept Signature,
silver with concept tonearm



concept Signature,
black with Satisfy Kardan tonearm

clearaudio compass

Leading the way to high-end sound

Clearaudio has always stood for uncompromising quality, ultimate precision, and exceptional design – handmade in Germany!

Now we are welcoming a wider audience for our high-end technology and performance with Clearaudio compass: a compact, attractively priced and easy to use turntable.

We have focussed our expertise on the essentials to deliver a vinyl-listening experience that far exceeds expectations in this price range. Compass features the new T1 tonearm – a smaller version of our acclaimed Satisfy – and a newly developed MM N1 cartridge.

At its core is a precision bearing in combination with a specially manufactured platter and sub-platter – crafted with the same attention to detail that defines all our products.

The turntable is delivered ready to play and comes equipped with a high-quality, detachable acrylic dust cover.

High-precision milled components, premium materials, and manufacturing quality built for longevity ensure years of musical enjoyment.

Clearaudio compass makes high-end audio accessible, without compromise.



Turntable compass, black



Turntable compass, silver

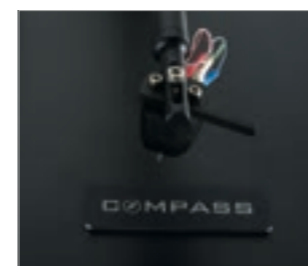

New MM Phono Cartridge N1



Antiskating of new T1 Tonearm



Precision sub platter / bearing incl. decoupled drive unit



Compatible Power input for additional Clearaudio upgrades



Pure feelings

Tonearms

Here at Clearaudio, we have developed new and better ways of satisfying the audiophile's needs. We offer an unparalleled selection of the three main types of tonearms: Single point bearing radial, multi-point bearing radial and tangential tonearms. Our range of tonearms features many cutting-edge technologies, including several Clearaudio patented designs. Even the radial tonearms deliver groundbreaking technology such as our magnetic bearings, as well as precision ball-race, unipivot, gimbal, and hybrid bearings.

Our sophisticated tangential technology is the perfect solution for those who really want to engage completely with the music and experience a flawless rendering of all facets of sound. Each LP master is tangentially cut in production by the record-cutting lathe. Clearaudio tangential tonearms operate according to our patented, purely mechanical passive process and follow the exact same tracking path as the cutter head that made the master. Replay tracking angles are thus identical and so mistracking distortion is virtually eliminated.



Statement TT1 & TT1 MI - Tangential tonearms: One becomes two

They call it the pinnacle of tangential tonearm technology: Clearaudio's patented Statement TT1 has been copied many times, but never matched. Now this state-of-the-art tonearm has been further enhanced and reengineered as two distinct editions: The Statement TT1, designed specifically for the Statement V2, and the TT1 MI, tailored for the Master Innovation turntable.

With the Statement TT1 and TT1 MI, records are replayed exactly as they were cut – following a straight line across the record. The cartridge's stylus is positioned at a perfect tangent to the record groove, guaranteeing zero tracking error. No skating force is generated at playback so no anti-skating compensation is needed.

In both editions, Clearaudio use a unique passive technology: The self-driven tonearm is mounted in a suspended carriage, a purely mechanical design that combines optimal resonance

values with maximum freedom from interference in the transmission of the music signal. The new Statement TT1 and TT1 MI now also feature an enhanced arm carriage, designed to further reduce friction. In addition, the suspension of the carriage has been adapted to enable the use of more shallow-bodied cartridges.

Only the finest materials earn their place in the Statement TT1 and TT1 MI. The resonance-optimised chassis is precision machined from bullet proof wood and aluminium. It glides backwards on stainless steel rails to allow record changing, then slides effortlessly back into the playback position and is held there with a magnetic locking system.

Uncompromising consistency and ongoing innovation make Clearaudio a pacesetter in tangential tonearm technology, always moving towards the perfect audiophile listening experience.



Tangentialtonarm TT1 MI, black



TT1 MI headshell



TT1 MI height adjustment



TT1 MI lift arm



TT1 MI detail



TT1 MI level gauge



TT1 MI tangential tonearm, silver

TT2 - Precise masterpiece

It takes hours to assemble the TT2 tangential tonearm. Clearaudio invests masterful production quality in this fine mechanical work of art, the basis for a hard to beat sound quality. The purely mechanical precision drive of the TT2 is based on two dry-running high-precision bearings and a polished glass tube that ensures almost complete freedom from friction.

The subtle finish in silver or black aluminium crowns the TT2's highly functional design. This tangential tonearm with its weight of nearly two kilograms is completely stable, can be finely adjusted in height and is elegantly simple to use. A massive masterpiece that transmits the information extracted from the record groove more precisely and faithfully than ever before, with a decisive impact on the authenticity of the music playback.



TT2 tangential tonearm, black

TT2 tangential tonearm, silver



Elegant cueing and precise height adjustment



TT2 cartridge carrier

TT3 - High-end introduction

The TT3 tonearm embodies the Clearaudio philosophy of uncompromising optimisation of the playback of records. It embodies total mechanical control and requires no power assistance. This guarantees a flawless musical signal without noise. Polished glass and extremely smooth bearings provide friction free movement of the cartridge and minimum resonance.

The TT3 shares with its bigger brothers in the TT range an integrated mechanism for fine height adjustment and elegant cueing. Experience the power of audiophile music reproduction with an astonishing lack of distortion – hear music in its purest form without compromise. The TT3 is available in silver and black finish.

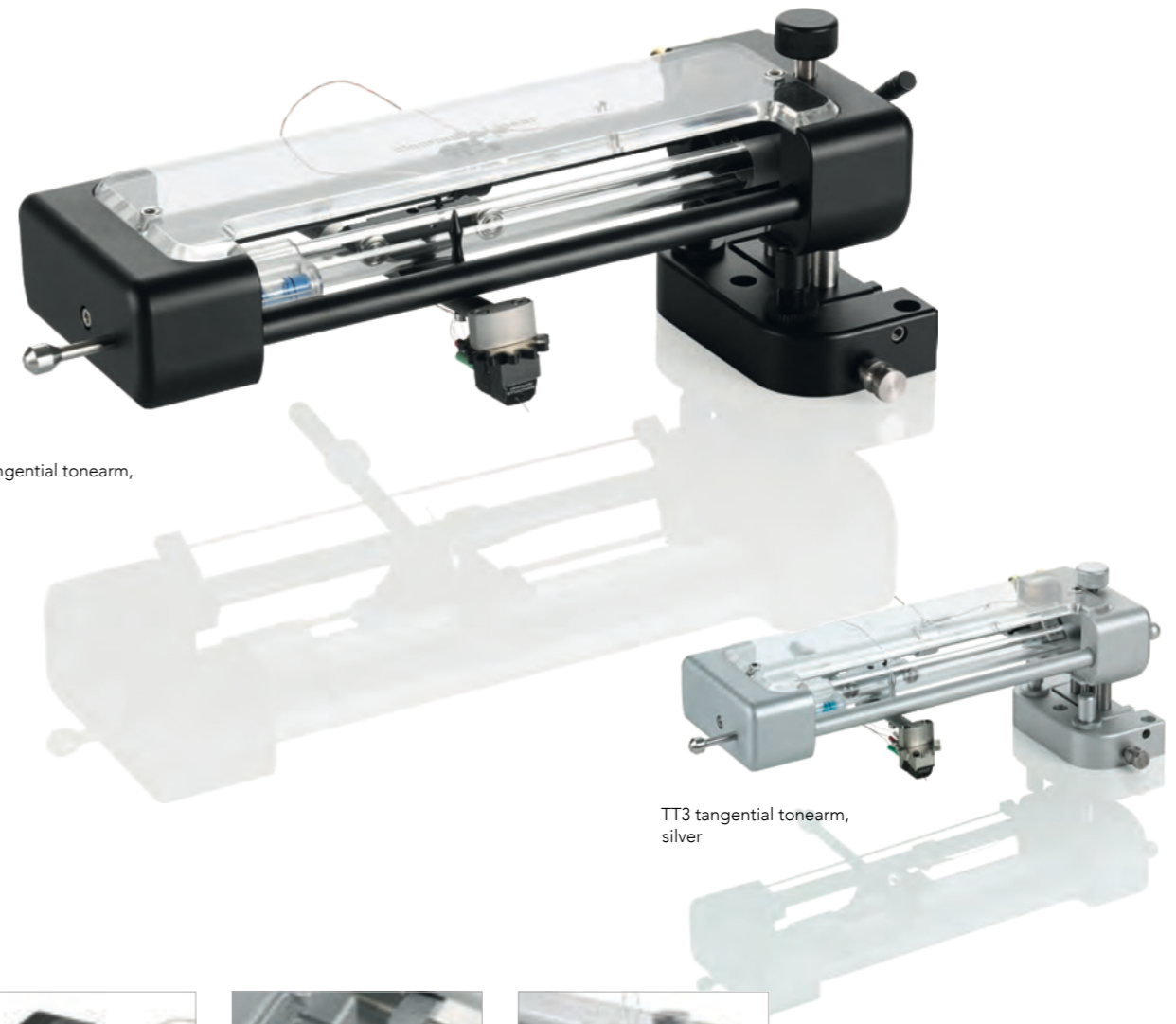

TT3 tangential tonearm, black

TT3 tangential tonearm, silver



TT3 cartridge carrier



Bubble level for precise tonearm adjustment



Elegant cueing and precise height adjustment

TT5 - High five

With the TT5, Clearaudio offers vinyl fans a more affordable entry point into tangential tonearm technology. The TT5's surprising and excellent value for money is down to eschewing one or two of the features of its bigger siblings, the TT2 and TT3. For example, the TT5 adopts a new, fully rigid design.

However, for those who like it convenient, Clearaudio has created the optional TT5 swing base which, as its name suggests, allows the entire arm assembly to be moved out of the way when changing records.



Tangentialtonarm TT5, black mit Swing base



Tangentialtonarm TT5, silver mit swing base



Schwingmechanismus des TT5 mit swing base

Unity – Private Dancer

As the name suggests, the new Clearaudio tonearm combines the proven single-point bearing with a newly developed magnet stabilization design. Thanks to this enhancement of the single-point bearing design, new performance standards are set for vinyl playback. All tonearm adjustments are now possible at the micron level, ensuring the most accurate alignment and perfect tracking for high-end cartridge systems.

The continuous height adjustment allows for convenient setup even during playback. This state-of-the-art tonearm will be available in black and silver colors, with a 10 inch Monocoque carbon tonearm tube, making it the perfect complement for all Clearaudio products as well as many other manufacturers.



Tonearm Unity, black

Tonearm Unity, silver



Tonearm Unity, black with Cartridge Diamond Jubilee



Tonearm Unity, black



Tonearm Unity, silver



Tonearm Unity silver with Goldfinger Statement V2.1 cartridge

Universal - Lightweight stability

A mechanical masterpiece of both design and functionality, Clearaudio's Universal (also compatible with VTA-Lifter) convinces by performance. High-precision ball bearings in the vertical and horizontal axes guarantee that the tonearm provides the perfect conditions for the cartridge to track the record groove without adding any colouration or distortion. The arm tube is made of carbon, ultra stiff but lightweight, providing maximum stability and perfect tracking. The easy and exact setting of azimuth and VTA are child's play – and

with the optional VTA-Lifter the adjustment of VTA can be done even while playing a record. The Universal is compatible with almost all popular cartridges, thanks to easily interchangeable counterweights and a fine scale which makes the precise adjustment of tracking force elegantly simple. The Universal is available in 9 inch and 12 inch lengths each in the colors silver and black. As an optional extra the VTA-Lifter is available in the corresponding colors.



Universal 9 inch tonearm, silver carbon

Universal 9 inch tonearm, black carbon with VTA-Lifter



Tonearm headshell and da Vinci V2 MC cartridge



Tonearm tube, made from extremely lightweight and highly rigid carbon fibre

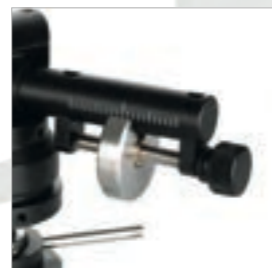

Any weight of cartridge can be accommodated by virtue of the easily interchangeable counterweights



VTA-Lifter

Tracer - Elegance meets ease

The Tracer radial tonearm may look beautifully minimalistic, yet beneath its sleek design you'll find a wealth of workmanship and a raft of smart details. Drawing on engineering tricks from the finest watchmakers, it features a high-precision, low-friction jeweled bearing, judiciously crafted from tungsten and sapphire. The carbon tonearm tube is both extremely rigid and very lightweight, giving a perfect combination of stability and agility. What's more, the Tracer's elegance does not come at the expense of usability – on the contrary.

The anti-skating force is effortlessly adjustable by way of a simple dial within perfect reach, while the aluminium headshell allows the azimuth to be easily fine-tuned. The counterweight is underslung providing an optimal centre of gravity and allowing straightforward adjustment of the tracking force. The Tracer is available in a choice of silver carbon or black carbon.



Tracer tonearm, silver carbon

Tracer tonearm, black carbon



Tracer radial tonearm, black carbon



Detail of Tracer tonearm, black carbon



Detail of Tracer tonearm, silver carbon

Profiler – The perfect companion



Profiler Tonearm, silver



Profiler Tonearm, black

Profiler Tonearm, silver

The Profiler tonearm represents the perfect symbiosis of the Satisfy Kardan and Tracer tonearm. Gaining clear improvement by combining the best elements of both tonearms as well as the standardization of components. Contributing to this optimization are the double bearing in the vertical bearing and the resonance protection dome. Therefore the Profiler tonearm represents the ideal link between the well-established Satisfy Kardan series and the new Tracer generation.

This outstanding piece of precision engineering is available in black and silver. The tonearm tube is made of lightweight high-quality aluminum alloy and is equipped with special damping points. The Profiler tonearm is the perfect companion for the Performance series and meets the highest demands.

Satisfy Kardan and Satisfy Kardan *Signature* - Direct to the heart



Tonearm Satisfy Kardan, silver aluminium

Tonearm Satisfy Kardan Signature, black carbon

At the heart of the Satisfy Kardan is something quite significant: Direct wiring, which allows the audio signal to travel uninterrupted and unimpeded along one single continuous path from cartridge to preamplifier. What's more, thanks to a pre-mounted aluminium headshell, the azimuth is a breeze to align. Anti-skating? Equally effortless, yet reassuringly precise. Magnetically adjusted, it is then fixed in place with an easily accessible locking screw neatly positioned next to the tonearm bearing. The vertical bearing features a polished tungsten spindle embedded in a meticulously balanced sapphire bearing (the latter is also used by Swiss clock manufacturers – which gives you an idea of its accuracy).

The two horizontal bearings are crafted using an exceedingly strong and durable ceramic material. Strong and durable it may be, but the Satisfy Kardan has also been designed for flexibility - in that it is combinable with a wide range of turntables and cartridges, allowing you to incorporate it into your current system with ease.

Whether you opt for the silver, black aluminium or carbon fibre edition, the Satisfy Kardan will get direct to the heart of your music.

Clarify - Smooth pleasure



Friction-free magnetic bearing



Clarify tonearm, silver carbon

If mechanical parts do not touch, there can be no friction. The Clarify tonearm uses magnetic bearings and is therefore completely frictionless. This Clearaudio innovation transmits even tiny signals without any interference and remains absolutely unaffected by resonances.

The Clarify can be used with virtually all cartridges with a weight from 2.5 to 17 grams, but reaches its maximum performance potential and richest sound when combined with the Ovation turntable and a Clearaudio moving coil (MC) cartridge.

Verify / concept - Elegant listening



Verify tonearm, silver carbon



concept tonearm, black aluminium



Verify tonearm, silver carbon

The Verify tonearm presents Clearaudio's innovative and groundbreaking magnetic bearing technology in an elegant package. Super solid, resonance-optimised carbon fibre is the basis for a user-friendly radial design. The aluminium resonancefree headshell can be finely adjusted; the finely adjustable counterweight sets the exact tracking force. Stylish design and clean lines make the Verify a stunning eye catcher as well as providing precise signal transfer and a calm, clear sound. This beauty is wired with a Clearaudio high-quality cable.

By combining the design of the Verify tonearm with a black aluminium tonearm tube, the concept tonearm was created and is now an essential part of the Clearaudio portfolio. This tonearm reaches its optimum sound when combined with the concept turntable and corresponding concept mc cartridge. For high-end music lovers and newcomers, this may be the most exciting complete turntable package of all time. But even on most other turntables the Verify embodies an affordable synthesis between breath-taking design and detail-rich sonority. Cartridges with a weight from 2.5 to 17 grams are ideal partners for the Verify.



Amazing stage

Cartridges - Close to the mystery of music



Clearaudio have been engaged in ongoing research into moving coil technology since 1978. Compared with moving magnet systems, moving coil cartridges have the potential to extract even finer details from the record groove and to respond to dynamic changes significantly faster. Since the early days of our research, the improvement of sound quality has been driven steadily forward by using new materials and seeking new solutions to well known problems, such as setting new standards in the parameters of dynamic impedance, inductance and capacitance. Ingenious design and extensive scientific experimentation have allowed us to bridge the gap in performance between moving magnet and moving coil cartridges. Our top-of-the-range moving magnet cartridges incorporate many of the features of our moving coil cartridges. The Clearaudio MC generation V2 represents the state of the art for high-end MC cartridges.

Perfect symmetry for perfect sound reproduction:
Clearaudio moving coil cartridge technology.

Only patented Clearaudio moving coil (MC) cartridges are symmetrical in all three important respects: Magnetic, mechanical and electrical.

Clearaudio MC technology is considered by both experts and music lovers to be the ultimate in audiophile music reproduction.

Since Clearaudio was founded in 1978 the team have pioneered a series of novel ideas, subjecting every new development to meticulous scientific examination and ruthless testing. This tireless refusal to accept limitations and to strive toward new solutions and higher fidelity have enabled Clearaudio to reach peaks of innovation and technological development and to occupy a leading market position.

Such outstanding specifications as a dynamic range of 100 decibels and a bandwidth of 20Hz - 20kHz speak for themselves. Countless hours are invested in our laboratories to make Clearaudio's flagship products even better and in so doing, the standard for the world's best to be redefined and many technological triumphs of analogue music reproduction have been achieved.

Each moving coil cartridge made by Clearaudio is an impressive demonstration of fine engineering and a milestone in high-end audio history: Unique masterpieces with microscopic pure gold coils, handmade in Germany.

Goldfinger Statement V2.1 – The ultimate dream

Clearaudio proudly presents the Goldfinger Statement V2.1 cartridge, which offers significant technological advancements for an impressive listening experience.

By integrating stronger magnets and a new selection process, the Goldfinger Statement V2.1 sets new standards in sound quality. Its precise reproduction and impressive detail make it an outstanding cartridge for discerning music enthusiasts. The redesign of the cantilever with an optimized angle contributes to improved tracking accuracy. Visually, the Goldfinger Statement V2.1 features a V engraving that underscores its simple elegance and modernity.

Another notable change lies in the precision of the new manufacturing process of the gold body, which provides even more geometric stability to the Goldfinger Statement V2.1. This cartridge deserves only the finest recordings of all time. The MC Goldfinger Statement (V1) was the first cartridge with integrated HF shielding. The high sound quality of this world-class cartridge is the result of meticulous detail improvements and fine-tuning of all values. The breakthrough came with the use of a 30% thinner 24-carat gold wire for the coils, a precision-ground gold bracket for securing the magnet block, and a body made of 585 gold – essential core components for the ultimate cartridge masterpiece. A valuable asset that will last for generations.



Images enlarged for viewing

Titanium V2 - A jewel for your eyes and ears

This exceptional cartridge represents a work of art for the ages: Its 95 decibel dynamic range delivers the optimum for current listeners and may well also set a benchmark for future generations. Through its technical perfection, the Titanium V2 embodies perhaps the most exciting combination of materials in audiophile history. Perfect resonance suppression is embodied within the twelve-finger platform design, which has become a standard-setter for aesthetic as well as functional design.

Thanks to the boron cantilever, Clearaudio Prime Line stylus shape and 24 carat gold coils in conjunction with a titanium body that weighs just eight grams, the highest linearity and transparency of analogue playback can be achieved with this gem of a cartridge. Audiophile dreams become audible.



da Vinci V2 - Innovative classic

Classic design for contemporary art. The aluminium body of the da Vinci V2 is characterised by its extra hard, 30 micron thick ceramic coating that delivers extremely efficient resonance suppression. Its interior is so unique that it has been patented: Eight magnets that provide massive focused field density guarantee perfect reproduction of audiophile recordings. The 24 carat gold coils of the da Vinci V2 are arranged in circular symmetry. This cartridge is an excellent example of combining cutting-edge research with meticulous craftsmanship to deliver outstanding results.

With a total weight of only seven grams, Clearaudio Prime Line stylus shaped, rigid boron cantilever and 90 decibel dynamic range, the da Vinci V2 provides all that is required to open up new horizons of sound dynamics and tonal homogeneity.



Images enlarged for viewing

Jubilee MC – Anniversary masterpiece

The Jubilee moving coil phono cartridge is the first Clearaudio cartridge with a body created from Panzerholz, a high-tech, natural wood product manufactured in Germany. This remarkable material already contributes to the exceptional performance of a number of our turntables, thanks to its high-density, high-strength and extremely low resonance. And yet, despite being dense enough to sink in water and strong enough to be bullet proof, Panzerholz is also surprisingly light in weight. Add to this a very special paint and polish finish borrowed from the elite violin makers of our local area, and you have a very fine 'musical instrument' indeed - a true marriage of cutting-edge technology and acoustic craftsmanship.



Images enlarged for viewing

Stradivari V2 - The height of precision

A name to live up to. Meticulousness of design, spurred on by a goal of redefining the best and raising the bar ever higher, have led to a masterpiece of German craftsmanship. An impressive 80 decibel dynamic range is made possible through the use of patented V2 technology and of the finest high-end materials.

This lightweight precision cartridge weighs only seven grams. It is the result of highly devotional microscopic craftsmanship – mastery of perfection in design and material selection. Important ingredients are a body of long-aged ebony, a precisely ground twelve finger platform and coils of 24 carat gold. The result: A stunning listening experience of almost unbelievable transparency and depth.

Concerto V2 - In the league of champions

With a dynamic range of up to 70 decibels and a total weight of only seven grams, the Concerto V2 qualifies itself for the top league of moving coil cartridges. Within this satin wood body the technology is outstanding, housing 24 carat gold coils and a patented eight-magnet array unique to our V2 range. Further champion-level ingredients are the boron cantilever and Clearaudio Prime Line. A recipe to win the trophy of sound championship.

Talisman V2 Gold - Simple, elegant, great

Due to its patented symmetrical arrangement of eight magnets and 24 carat gold wire coils the new Talisman V2 Gold redefines the performance available at this price level and reveals the sonic potential of the second generation 'V2' series of Clearaudio moving coil cartridges. The legendary combination of a rigid boron cantilever and Clearaudio Prime Line diamond shape extract even the finest details stored in the record's groove both effortlessly and meticulously to deliver an unprecedented performance. The 10.8 gram hand-polished ebony body not only impresses with its discreet elegance, but also contributes to the clear, captivating sound of this cartridge by perfectly suppressing resonances.



concept mc *Signature*

To bridge the gap between the entry-level MC cartridge, the concept mc, and the high-end Talisman V2 Gold, the individual components of the concept mc Signature, as with its predecessor, the essence mc, are subjected to rigorous testing and selection. This meticulous process ensures that the concept mc Signature meets the highest quality standards and delivers exceptional sound reproduction. By precisely tuning the components, it is guaranteed that the concept mc Signature not only meets the expectations of the most discerning audiophiles but also offers impressive performance and reliability. This results in a cartridge that is an excellent choice for both beginners and experienced music enthusiasts.



concept mc - Reduce to the maximum

The concept mc combines high-quality moving coil technology with a minimalist design. Here, audiophile explorers discover what the optimisation of magnetic circuits can deliver: This cartridge releases crystal clear sounds and represents nothing less than a revolution in its class. Equipped with a boron cantilever, the concept mc has channel matching to within half a decibel, 11 ohms internal impedance and is fitted with a Micro line stylus – features normally unheard of in this price range. All of which adds up to make this high-quality cartridge a bargain for the cost-conscious high-end fan.



Images enlarged for viewing

MM cartridges

Clearaudio's V2 MM technology uses ebony as a resonance-resistant body. Other ingredients of the recipe for success are the most effective reduction of moving mass, an optimised polishing technique for the stylus and highly effective cartridge damping. This is precision engineering in the pursuit of the best sound.

The Clearaudio V2 moving magnet cartridges are meticulously measured, analysed, and hand-selected into four performance levels. In this way Clearaudio achieves the best stereo channel matching, minimum phase error and distortion, flattest frequency response and highest dynamic range at each price point. The cartridges produce an audiophile sound of superlative quality – spatially detailed and vividly textured, with bass that does not wallow and treble that is not harsh. The models of the Clearaudio MM V2 series provide outstanding sound quality on all current tonearms.

With the exception of the concept V2, which is made of aluminium, all the cartridges of the V2 series are made with housings of hand-polished ebony - the key to record-breaking weight values with an average of 8.4g. This is what Clearaudio calls "effective reduction of moving mass".

Like the Jubilee MC, our moving magnet / MM edition also features a body expertly crafted from Panzerholz, along with the same special paint and polish finish borrowed from our local Franconian violin makers. And if you're wondering about the name, the 'Jubilee' MC and MM phono cartridges have been created to mark Clearaudio's 40th anniversary, recognising four decades of dedication to 'loving music' – which always worth celebrating.



Charisma V2



Maestro V2

Images enlarged for viewing



Virtuoso V2



Jubilee MM

Images enlarged for viewing



Artist V2



Performer V2



concept V2

ready for LIVE



Electronics

Being specialised in analogue music playback, it is our responsibility to promote continuous technological development to create improved standards that establish audiophile listening pleasure at its highest level. Perfection in manufacturing and measurement is reflected in a superior sound: The purest listening quality, and the reason we put our concentration on even the tiniest detail.

Without exception, our phonostages are constructed using carefully selected components of the highest material quality. At Clearaudio, to avoid any of the performance-limiting effects of mains electricity, all our power supplies are separated from the sensitive circuits. Clearaudio amplifiers are equipped with our own non-magnetic RCA plugs. Why? Because those who strive for excellence must be prepared to lead the way.



statement phono - Top class for top demands

The statement phono is established at the absolute top - where the air is thin, but the sound quality reaches its maximum density. From the deepest bass to the highest treble, from the additional bass octave of an imperial grand piano to the piccolo flute of a full church organ and beyond, the statement phono presents sounds exactly as they are. It takes nothing away and does not add anything, but embodies the ideal of pure music reproduction. Silver mica capacitors ensure that the signals are handled without loss. Only the most noise-free resistors and capacitors, carefully selected, are worthy to take their place on the circuit boards of this monumental 34 kilogram phonostage.

This phonostage does not compromise. But it does allow you to connect and control the volume of all major sources via two phono inputs and two additional analogue inputs. For power, an external battery power supply is used, so that interference from the mains electricity does not exist. The statement phono embodies the ultimate truth of listening, and with its switchable input resistors and freely adjustable equalisation curves, addresses the needs of discerning analogue fans that want to extract the best sound from their records. This sound laboratory in miniature is unique and unmatched in the analogue world.



statement phono



statement phono,
rear view



statement phono controls



statement phono remote control

balance reference phono

The new balance reference phono was developed especially for the phono enthusiast, featuring completely independent phono inputs for connecting moving coil and moving magnet phono cartridges. It provides total freedom in selecting balanced (XLR) or single-ended (RCA) inputs and outputs with the total flexibility of adjusting the input impedance for most cartridges.

The sophisticated volume and input circuitry are accessible with the supplied remote control. The high-performance design provides 2 headphone connections. A dual-mono power supply housed in its own dedicated aluminium chassis assures the highest sound quality. The balance reference phono is truly a world-class phono stage for analog aficionados.



balance reference phono, silver



balance reference phono, black



balance reference phono, remote control, silver



balance reference phono, silver rear view



Setting options on the bottom side



balance reference phono, black rear view



Setting options on the bottom side

balance V2

How do you balance simplicity with complexity? Clearaudio's balance plus phono stage managed it with ease and now the balance V2 advances its technologies while losing none of the equilibrium. On the one hand, its design remains elegantly unfussy and its operation effortlessly intuitive. And yet at the same time, the balance V2 offers an array of options to adjust and fine-tune its performance to your particular system and preferences.

The sleek casing is crafted from precision-milled aluminium, which is also available with an anodized black finish. As well as the usual RCA outputs, the balance V2 features balanced XLR outputs and a 6.3 plug headphone output. All RCA inputs and outputs are gold-plated for superior signal transmission. Besides the manual volume control you can choose between mute and automatic mode by button.

A simple switch allows you to choose between moving magnet and moving coil mode. From there, the balance V2 will automatically harmonize with almost any high-end phono cartridge without you needing to make any further adjustments. High-precision RIAA equalization achieves an accuracy of within 0.1dB, while an optional subsonic filter attenuates any unwanted low frequency noise. A separate power supply in its own aluminium casing keeps any potential unwanted interference at bay.

With this small yet high-performance package, Clearaudio effectively balances audiophile-quality technology with a simplicity that can be enjoyed by any music enthusiast. Just take a seat and enjoy.



balance V2, rear view

basic V2

There's nothing basic about the basic V2 phono stage. Don't be fooled by its cool, minimalist design. Within that sleek aluminium casing (with silver or black anodized finish) lies an inner world of highly refined features. Its predecessor, the basic plus, was a multi award winner and with the V2 we've taken all of that coveted 'Plus' technology up a notch. On the outside, we've kept it very simple. There's just one visible control, a single power switch on the upper surface that opens up a raft of possibilities. On the underside you can switch between moving coil and moving magnet mode.

From there, you can easily enjoy the basic V2 with almost any high-end phono cartridge without making any further adjustments or you can choose from a range of performance enhancing settings to fine-tune its parameters to your system and your heart's content. An optional subsonic filter attenuates any unwanted low frequency noise, while RIAA equalization accuracy is within 0.1dB. All of which adds up to the basic V2 being the perfect all-rounder for both audiophiles and music lovers.



basic V2, silver



basic V2, black



basic V2, rear view

smart phono V2

smart phono headphone V2

A minimalist aluminium housing that contains one of the best sounding phonostages in its market. Up to 54 decibels gain at one kilohertz and an extremely linear frequency response deliver unprecedented quality at this price point. For MM and MC cartridges there are two separate circuit designs using

SMD technology, which are selected by a slide switch on the underside. A light 620 gram phonostage that seduced the worldwide audio press. The only thing that is 'entry level' about this product is its price. The smart phono V2 is also available with headphone output.



smart phono headphone V2, silver

smart phono V2, black



Setting options on the bottom side



smart phono V2 / smart phono headphone V2, rear view

nano phono V2

nano phono headphone V2

The nano phono V2 phonostage isn't ruffled by anything. External interferences are no longer an issue with this fine piece of engineering. Its meticulously selected SMD components are assembled by hand in Erlangen and tested several times. The reward of these efforts is a signal to noise ratio of up to 84 decibels.

The input impedance is set using plug-in links, so there is no loss of quality when using different moving magnet and moving coil cartridges. The nano phono headphone V2 additionally contains a powerful headphone amplifier within the solid aluminium housing for private listening at the highest fidelity.



nano phono headphone V2, silver

nano phono V2, black



Setting options on the bottom side



nano phono V2 / nano phono headphone V2, rear view

smart power 24V

The smart power 24V is a battery-based DC power supply upgrade, designed to unleash more of the considerable potential of Clearaudio's high-performance Ovation, Innovation and Statement turntables. It partners intelligent circuit technology with long-lasting NiMH (nickel-metal hydride) rechargeable batteries to deliver 24 volt of pure, clean, fluctuation-free power.

The smart power 24V can be set to switch automatically from battery play mode into recharging mode if desired. Even when recharging, it continues to offer an improvement in sound quality as well as adding safety features such as protection against short circuits and overvoltage. Its elegant, low-key design includes a dimmable LCD display.

smart power 12V

Like the smart power 24V, it provides clean power that is independent of the variability and inherent noise of the mains supply. With a minimal output impedance, it delivers a steady, stable voltage, allowing your concept or Performance DC series turntable to maintain perfect speed stability. Again, like the 24V version, the smart power 12V can be set to switch automatically from battery play mode into recharging

mode and will continue to enhance your turntable's performance and protect it from short circuits and power surges, even while charging. When used with the concept active turntable, the smart power's (12V) benefits are multiplied, since both the turntable's motor and the on-board phonostage are fed with pure, clean DC power.



smart power 24V, black



smart power 24V, silver



smart power 12V, black / black



smart power 12V, black / silver

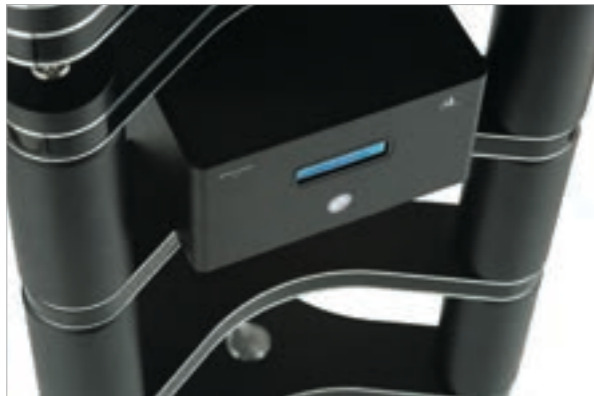

smart power 24V on Innovation Series Stand



smart power 24V, rear view



Display smart power 24V



smart power 12V, rear view

Professional Power 24V

The Professional Power 24V is a high-quality transformer-based and stabilized 24 Volt DC power supply. It is designed to fill the gap between the standard power supply that comes with our turntables and our state-of-the-art, auto-charging smart power 24V battery supply.

The Professional Power 24V provides improved filtering over the standard power supply, which delivers a much cleaner power source. Cleaner power and increased 'headroom' for

Clearaudio's Innovation and Ovation series turntables, thanks to a smoother motor performance and extended reserves. The resulting improvements in sound quality are significant.

The unit's construction features professional-grade electronic components and a resonance-optimized transformer to ensure that no mechanical interference will be transferred through the housing. The attractive design and improved listening experience will ensure that the Professional Power 24V is a welcome addition to your home audio system.



Professional Power 24V, black



Professional Power 24V, silver



Professional Power 24V, silver, rear view



Professional Power 24V, silver, detail

Professional Power 12V

The Professional Power 12V Power Supply from Clearaudio sets new standards in power supply for turntables of the concept and Performance DC series. This transformer-based and stabilized 12-volt DC power supply offers outstanding filtering and sufficient capacity to ensure optimal motor performance. The purified analog power source of the Professional Power 12V power supply provides extended reserves and even smoother motor performance, leading to a significant improvement in sound quality.

Designed to bridge the gap between the standard power supply and the smart power 12V, this power supply offers unparalleled performance and reliability.

The electronic design features include high-quality electrical components and a resonance-optimized transformer that ensures no mechanical resonances are transmitted through the housing. This guarantees a clear, natural, and unadulterated sound experience that meets the highest standards.



Professional Power 12V, black



Professional Power 12V, silver



Professional Power 12V, black



Professional Power 12V, black, rear view

Terra

Every device in the household has the potential to introduce interference in the high-frequency range, which can be a potential disruptor for clean music enjoyment. However, often the fault lies within the hi-fi chain itself, which can generate unwanted humming. This is usually due to a missing or incorrect grounding. The new grounding system „Terra“ by Clearaudio is our solution to consolidate all necessary groundings at one point and leave possible ground loops in the past. The star-shaped endpoint prevents any ground loops, and the sand-filled casing additionally protects against vibrations and interference.

Through a special grounding plug, the device is grounded via the power outlet but is not directly connected to the electricity.

On the back of the „Terra“ grounding device, there are three connections for direct grounding (grounded) and three connections with potential difference (ground lifted). Additionally, three grounding cables are included in the delivery.

Small device, big impact - with its 91 millimeter diameter, the black or silver anodized housing effortlessly complements the aesthetics of any system.

Power Terminal

High-quality power strips are often neglected in hi-fi and home theater systems and electromagnetic and high-frequency disturbances can affect the quality of playback from the very beginning.

Clearaudio offers an all-in-one solution with the Power Terminal. The power strip offers a total of seven slots (1x 100W for turntable motors, 2x 800W for power amplifiers, 2x 200W for analog devices, 2x200W for digital devices), which are also individually grounded in a star shape.

The connection to the power grid is made via a shielded power cable. Thanks to a DC blocker, phase control, surge and lightning protection, your hi-fi system is safely and cleanly supplied with power.

The power strip is offered in black or silver anodized colors and can be mounted either vertically or horizontally (on the wall or the stand of your system).



Terra, silver

Terra, black



Power Terminal, silver

Power Terminal, black



Terra, silver rear view



Terra, Power plug



Terra, black rear view



Power Terminal, Power plug



Power Terminal, Connector



Power Terminal, detail

Record Cleaning

Records are valuable documents and important cultural artefacts. They deserve sympathetic care to preserve their sound quality - which, to date, has still not been matched by any digital playback systems. For high-end audio fans, a record-cleaning machine is an essential piece of kit to ensure vivid sound quality without crackles and to preserve the long life of your records.



Record groove before cleaning



Record groove after cleaning

double matrix professional SONIC - Deep record cleaning with sonic option

The cleaning of vinyl records is a key discipline in maintaining a high-quality record collection and Clearaudio's research and development team continue to strive for the perfect equipment for this job. The double matrix professional SONIC is our best solution yet.

The Sonic refers to a sonic option, in which sonic vibrations enable deep cleaning while being gentle and almost noise-free. Variable speed operation and static electricity removal as part of the cleaning process ensure perfect results.

Like a camera with dual automatic and manual functions, the double matrix professional SONIC offers the possibility of operating the whole cleaning process at the touch of a single button, as well as the ability to control each step in the process with a user-friendly operating panel.

The cleaning head and the automatic cleaning programs are optimized for 12" records of various thicknesses. Smaller records (7" and 10") can be cleaned with the manual cleaning mode without changing the cleaning head.

Another improvement is the removable microfibre carrier of the cleaning and vibrations pads, which enable effortless exchange of the microfibre stripes. An LED light indicates the cleaning fluid level in the internal tank and, as an additional precaution, the suction turbine features overheating protection.

Made from high-quality and heavy-duty materials, the double matrix professional SONIC is designed for continuous operation, so that record collectors and traders can clean complete record collections. And yet it is incredibly easy to use and maintain.



double matrix professional SONIC,
silver



Cleaning and vacuum unit

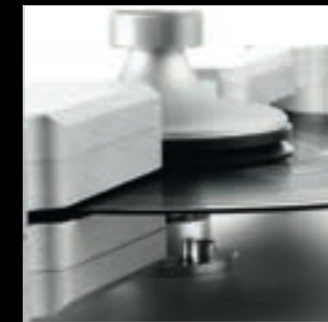

Innovative washing unit



Level indication LEDs



Antistatic unit



Comfortable control panel



Multifunction button
with blue LED ring



double matrix professional SONIC,
black

smart double matrix – High performance, compactly implemented

Great performance, compactly implemented. The smart double matrix cleans your most valuable treasures on both sides in just one wash cycle. Inspired by the basic idea of the double matrix professional SONIC, the washing unit enables the cleaning of all record sizes, as the application surface can be adjusted by a controller in the washing unit. Also included in the delivery is a robust clamp with label protection to protect the labels of your records from damage or moisture during cleaning.

The application of the cleaning fluid is done at the push of a button, and the duration and intensity of the cleaning are determined by the user themselves using the intuitive buttons. Visually, the new washing machine impresses with its elegance made of black, satin-finished acrylic.

A quite suction turbine inside the simple housing powerfully dries the record. The new washing machine also contributes to resource efficiency: The production of the storage and collection containers takes place entirely in our own production facilities. For the first time in Clearaudio's history, 3D-printed components are incorporated into series production.

With the new smart double matrix, Clearaudio deliberately renounced expensive automatic programs, level indicators and vibration modules during development. Thus, the latest model of the successful Clearaudio Matrix Generation aims to make quick and double-sided cleaning affordable for everyone.



smart double matrix,
black



smart double matrix,
black



Comfortable control panel



Cleaning and vacuum unit for double-sided cleaning, closed



Filling opening for storage container



Cleaning and vacuum unit for double-sided cleaning, opened



Drain hose on the rear



Brush for electrostatic discharge



Zubehör

Each music lover is different and so we would never presume to dictate what an individual listener 'should' want to hear. There is no single perfect setup. On the contrary, 'perfection' to us means that every individual's 'sweet spot' can be enjoyed to its full potential. That's why we offer such a wide range of options in our accessories – to allow any and every variation of fine-tuning.

Every detail counts in the search for the ultimate listening experience. From level gauges to record clamps and stylus cleaners to test records, every last one of our accessories is developed to the absolute best of our knowledge. Every connector, every cable, every counterweight – each product is a challenge, an inspiration and a delight to conceive and create.



Cables

Only those who work with the utmost meticulousness on the improvement of music playback know the extent to which power and signal cables influence the sound quality.

Since the early days of Clearaudio, our engineers have undertaken ongoing research aimed at steadily improving the combination of music playback components and perfect power sources. On the way to absolute perfection, the Clearaudio developer clearly analysed which factors are needed to create the perfect tonearm cables:

Absolute flexibility to allow any movement of the tonearm without interference. Cables and insulation meet the highest quality standards. The cable must be microphone-resistant on its whole length and through ideal shielding any impairment of the energy transport is avoided.

The result is presented in a range of cable connections and special elements for clearly defined types of signals. Clearaudio has the optimum cable for every need, from phono signals of small amplitude up to the massive power supply that needs high power connectors of the most sophisticated design.

Our know-how guarantees perfect insulation of the signal conductors, 100 per cent phase consistency and perfect channel balance. This makes the perfect sound: Distortion-free, clear and natural.



Connectors

RCA plug

The non-magnetic direct gold plated beryllium copper of this RCA plug guarantees an undistorted signal flow, providing the perfect partner for all RCA phono sockets.

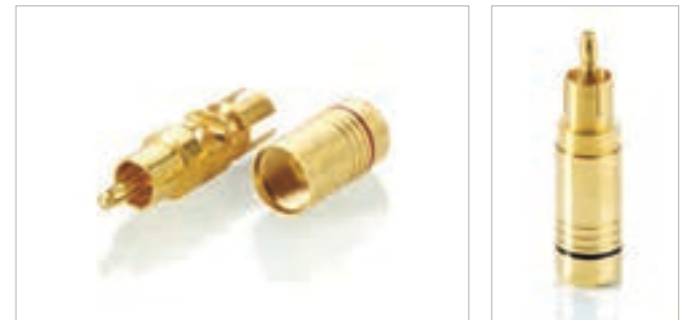

Tonearm cable connector (DIN 5-pole)

A truly high-end 5-pin tonearm cable connector exquisitely manufactured from non-magnetic materials and finished with a pure gold plated surface. Precision sprung internal contacts ensure a perfect connection between tonearm and cable, maintaining the highest fidelity of the delicate phono signal.

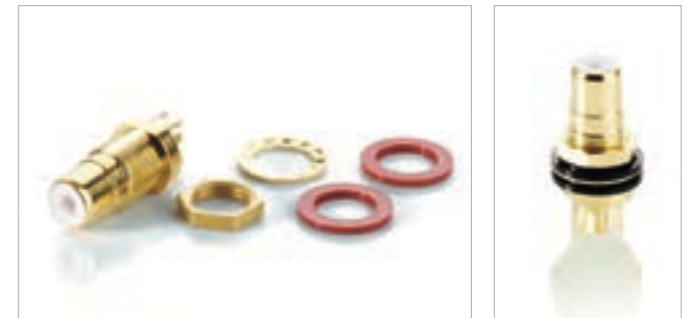

RCA socket

The non-magnetic beryllium copper body together with Clearaudio's special gold plating process ensure that this RCA phono socket offers supreme audiophile quality.

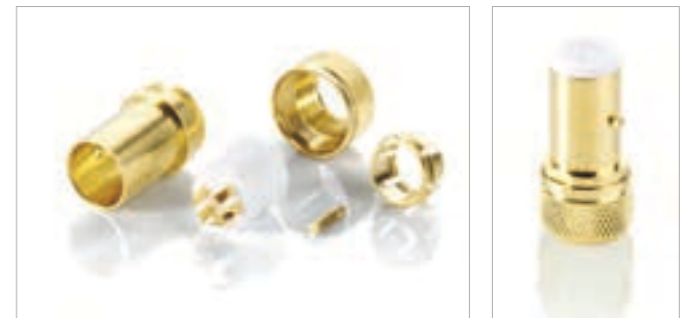

Cartridge pins

The delicate low-level signals from a phono cartridge need precise and very secure connections. Differing diameters of cartridge pins are accommodated by the spring-loaded fit of this connector, ensuring that no vital information is lost.

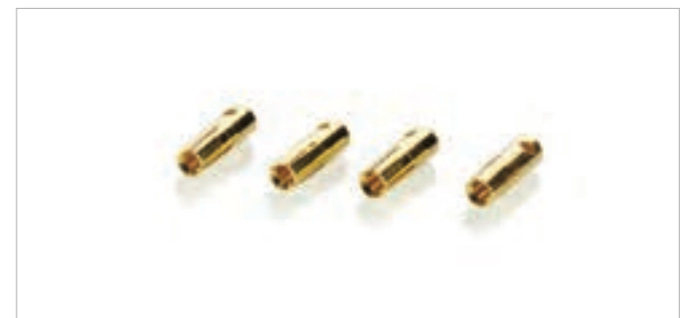

Innovation Series Stand

Clearaudio stands for excellent listening pleasure – and visual appeal. Therefore, we design our stands as highly functional home accessories for aesthetes: Elegant and timeless in their appearance and well constructed down to the smallest detail. Only the best materials such as solid aluminium and bullet proof wood are used to achieve the highest possible quality. Each platform is further enhanced with aluminium surface plates. Even your heaviest devices will rest comfortably.

Very solid spikes decouple Clearaudio stands so effectively that they remain totally unaffected by resonance. Each stand can be designed to be flexible in the number of levels and the total height. And your listening experience will reach a new level.



Innovation Series Stand, black with Master Innovation



Innovation Series Stand, black



Innovation Series Stand, silver



Rack detail, black



Rack detail, silver

Accessories

Headshells, alignment gauges, tonearm base, cleaning and maintenance. We've got it all covered. But it's up to you – music lover, audiophile, aficionado – to decide on the specific combination of instruments that will allow you to achieve 'your' perfect sound. We're honoured to help, and delighted to know that our lovingly-crafted products will end up in such expert hands.



Professional Analogue Toolkit



Professional Turntable Care Kit



Smart stylus precise cartridge tracking force gauge



Weight Watcher touch digital cartridge tracking force gauge



High precision level gauge, stainless steel



Precision level gauge, mounted in a stainless steel ring



Mini Level Gauge



Precision level gauge, basic version



Clearaudio Break-In Testrecord



Clearaudio Speed Light V2



Clearaudio Trackability Testrecord



Speed Light V2 with Stroboscope test record



Cartridge and tonearm IEC alignment gauge



Multi Installation Gauge for radial tonearms (incl. Stroboscope and Speed Light V2)



Magnifying glass



Tangential alignment gauge Available in silver and black

Zubehör



Carbon fibre brush, antistatic



Pure Groove brush



Dustprotector for turntable platter



Perfect Points, silver (also available in black)



Ceramic Magnetic Bearing (CMB)



Stylus cleaning brush



LP Drill



Dustcover, acrylic, different sizes available



Universal silicon belt, available in different lengths with 1 or 2mm diameter

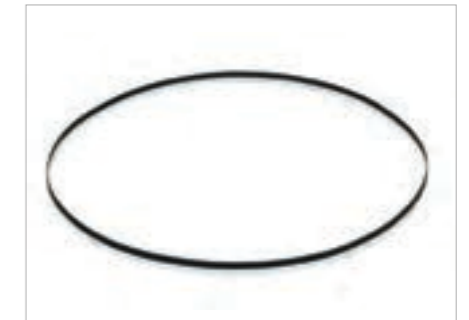

Calibrated flat belt available in different lengths



Clear Contact, electronic contact cleaner



Diamond cleaner - Elixir of Sound



Headshell with SME-connection, including cartridge leads



Headshell cable set (also available in copper)



Polish Paste



Bearing Oil



Professional record cleaning fluid, available in various sizes for vinyl or shellac



Turboweight counterweight for radial tonearms



VTA-Lifter, perfect height adjustment for radial tonearms (also available in black)



Armboard for radial tonearms (silver)



Replacement microfibre stripes for all Clearaudio record cleaning machines



Armboard for radial tonearms (silver)



Armboard for radial tonearms (black)



Armboard for radial tonearms (black)

Zubehör



concept record weight, 215g



Clever clamp, record clamp, 20g



Quadro clamp record weight, stainless steel, 360g



Single adapter, precision machined, stainless steel



Outer Limit with Locator



Vinyl Harmonicer turntable mat



Twister record clamp, 190g



Performance Weight, record weight



Quadro clamp, record weight, flat version, stainless steel, 242g



Clamp mat brown, Ø approx. 101mm



Clamp mat black, Ø approx. 101mm



Innovation tangential record weight, black



Innovation tangential record weight, silver



Leather Mat black, Ø approx. 293mm
also available in brown



Felt mat



Statement record weight, ebony, 765g



Innovation record weight, black, 740g



Statement record weight, natural wood, 765g



Innovation record weight, silver, 740g



Vinyl Travel Bag



Record bag



Professional Vinyl Travel Bag

Company

Welcome to the circle of winners! Every Clearaudio product comes from a family with many winners. Awards from the global audiophile press as well as internationally acclaimed awards such as the Red Dot Award and the Design Award of Germany, grace many Clearaudio developments.

We see this as both recognition and further incentive for our continuing research to find the most perfect sound reproduction. These awards also validate our belief that the fine art of music demands mechanical masterpieces made with sophisticated craftsmanship and a genuine love of music. For more than 45 years we have been creating and manufacturing high-end solutions for people who share our love of music, with the aim of ensuring your ultimate listening experience: Audible, palpable and even clearly visible in our advanced designs.

The standards we set ourselves are high – in design, aesthetics, function, quality and service. Your audiophile needs are our constant inspiration for new, reliable components that reflect sound reality as closely as possible. Existing products are retested continuously and optimised in detail. Our prototypes run through sophisticated test phases in which all product characteristics and parameters are analysed and perfected. Only when we are absolutely confident of quality and performance are our products released to the market.

Our commitment to the exceptional performance of our products is reflected in generous warranty services.



Company



High specialised staff, the highest quality materials, skilful workmanship, uncompromisingly accurate design and ingenious production technology – all taking place in Erlangen, centre of science and location of the world-famous Friedrich-Alexander University. Our city shapes and influences our aspirations and expertise.

In close proximity to the Fraunhofer and Max Planck Institutes, our engineers and mechanics research future technology – for ever greater acoustic quality. Under the Clearaudio banner, highly trained perfectionists with innovative imaginations help to make audiophile visions come true.

To reach this aim, our technicians and engineers collaborate with a wide range of experts – including precision engineers, watchmakers, electronic engineers, physicists and industrial designers. The finest materials are then intelligently combined to produce impressive forms, parts and products that bear the unmistakable signature of Clearaudio. To preserve this signature for generations to come, we share our knowledge with ambitious young trainees. As a leading training company, we take social responsibility. With our headquarters in the Meilwald nature reserve we are even pioneering ecological sustainability.

You deserve the best: Outstanding sound, flawless perfection. To achieve this maximum in performance and durability, Clearaudio invests a large amount of time. Analogue music playback is a demanding and specialised area of craftsmanship which requires considerable patience in order to achieve maturity in development and production.

To maintain our commitment to quality, we produce most of our precision components in-house. This requires ongoing investment in production capabilities and provides independence from third party manufacturers – fundamental pillars of the Clearaudio philosophy, and the only way to ensure consistency, clear documentation, enduring quality and traceable results.

To reliably and precisely determine all measured data values, our engineers and technicians rely on leading technologies and methods. When standard measurements are insufficient to meet our needs, our in-house engineers develop our own measuring devices, working closely with external researchers to meet the high demands of Clearaudio performance.

This philosophy is the basis for stunning innovation and growing perfection.

Company

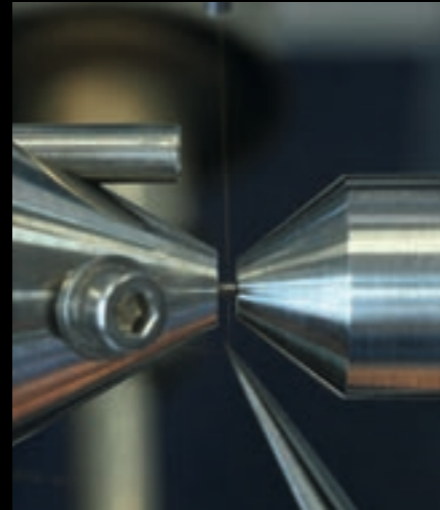
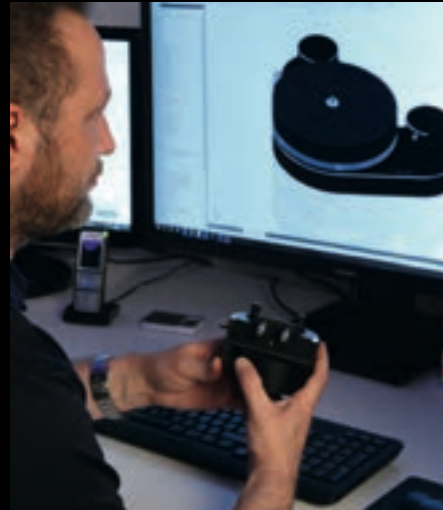

To ensure the highest level of quality, we must be able to monitor every step of the manufacturing process in real time. This is why we rely on in-house craftsmanship. Only a tiny proportion of our components are externally sourced – all exclusively from certified and specialised suppliers, usually found as locally as possible. All such component parts must fulfill strict Clearaudio requirements. Each product line undergoes a number of test steps. During the development of materials, continuous performance tests ensure optimum results. Clearaudio products leave our factory only after a careful and protocolled module test. All of which means that product faults are extremely rare, but even so we retain all spare parts for up to 10 years after product launch – a unique service appreciated by our customers.

In accordance with worldwide distribution requirements, Clearaudio's products meet all international guidelines. We combine passion with responsibility. Although our products are globally unique and distinctive, they adapt perfectly to the individual requirements of audiophile music lovers all around the world.

Through this sophisticated strategy we fulfil our goal to support the preservation of analogue music reproduction, the importance of which has experienced renewed growth in recent years. Worldwide enthusiasm for audiophile listening is once again on the rise.

Clearaudio delights in this development and will continue to drive it forward actively as a high-end audio pioneer.

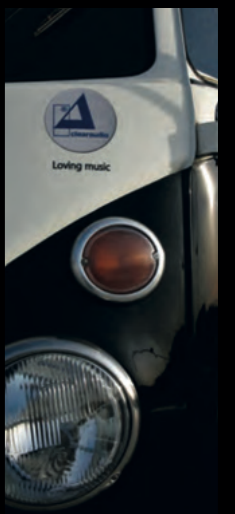
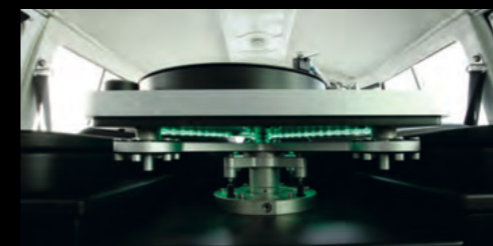



live on stage

Technical Specifications

Turntables I



Model:	Statement V2	Master Innovation
Construction details:	Aluminium, stainless steel and bullet proof wood	- Resonance-optimised chassis shape - Made of bullet proof wood and aluminium - All turntable feet are finely adjustable - Playback with three tonearms possible
Speed options:	33 1/3, 45, 78rpm	33 1/3, 45, 78rpm
Drive unit:	- High-torque 24V DC motor, belt-driven - Magnetic coupling of turntable and additional drive platter	- High torque 24V DC motor; belt-driven - Magnetic coupling of turntable and additional drive platter - Optical Speed Control (OSC) in real time through infrared sensor
Bearing:	- Inverted bearing in lower drive platter - Clearaudio patented ceramic magnetic bearing (CMB) in main platter / upper drive platter assembly	- Inverted bearing in lower drive platter - Clearaudio patented ceramic magnetic bearing (CMB) in main platter / upper drive platter assembly
Platter:	98mm / 3.86 inch main platter, made out of synthetic material with high-density and excellent dimension stability // precision CNC machined surface, solid stainless steel sub-platter, dynamically balanced	70mm / 2.75 inch main platter, made out of synthetic material with high-density and excellent dimension stability // precision CNC machined surface, solid stainless steel sub-platter, dynamically balanced
Speed accuracy (measured):	< ± 0.03%	< ± 0.05%
Power consumption:	Max. consumption: 19 watts Consumption in operation: 8 watts Off mode: 0.0 watts	Max. consumption: 9.5 watts Consumption in operation: 4.1 watts Standby mode: 2.4 watts Off mode: 0.0 watts
Total weight:	Approx. 350kg (without tonearm and power supply)	Approx. 60kg (without tonearm and power supply)
Dimensions (W/D/H):	Approx. 27.17 x 24.41 x 52.17 inches (with TT1 tonearm)	Approx. 18.11 x 19.09 x 15.59 inches (with tonearm base, without tonearm)
Dimensions (W/D/H):	Approx. 690 x 620 x 1325mm (with TT1 tonearm)	Approx. 460 x 485 x 396mm (with tonearm base, without tonearm)
Manufacturer's warranty:	10 years*	5 years*

Turntables II



Model:	Ovation	Performance DC
Construction details:	Resonance-optimised body, bullet proof wood chassis in sandwich construction embedded between two aluminium plates.	Resonance-optimised body, highly compressed wood chassis in sandwich construction embedded between two aluminium plates.
Speed options:	33 1/3, 45, 78rpm	33 1/3, 45, 78rpm
Drive unit:	- High torque 24V DC motor - Optical Speed Control (OSC) in real time through infrared sensor - Flat belt drive	- Decoupled and resonance damped 12V DC motor - Flat belt-drive - Plug-in power supply unit designed for worldwide use with all networks and power frequencies.
Bearing:	Inverted bearing with polished ceramic shaft in a sintered bronze bushing, Clearaudio patented ceramic magnetic bearing (CMB)	Inverted bearing with polished ceramic shaft in a sintered bronze bushing, Clearaudio patented ceramic magnetic bearing (CMB)
Platter:	40mm / 1.57 inch main platter, made out of synthetic material with high-density and excellent dimension stability, precision CNC machined surface, aluminium sub-platter	40mm / 1.57 inch main platter, made out of synthetic material with high-density and excellent dimension stability, precision CNC machined surface, aluminium sub-platter
Speed accuracy (measured):	± 0.03%	± 0.05%
Power consumption:	Max. consumption: 8.6 watts Consumption in operation: 2.5 watts Standby mode: 2.5 watts Off mode: 0.0 watts	Max. consumption: 3.3 watts Consumption in operation: 1.6 watts Standby mode: < 0.5 watts Off mode: 0.0 watts
Total weight:	Approx. 13.5kg	Approx. 11.0kg
Dimensions (W/D/H):	Approx. 16.54 x 13.78 x 5.31 inches (without tonearm)	Approx. 16.54 x 12.99 x 4.92 inches (without tonearm)
Dimensions (W/D/H):	Approx. 420 x 350 x 135mm (without tonearm)	Approx. 420 x 330 x 125mm (without tonearm)
Manufacturer's warranty:	5 years*	5 years*

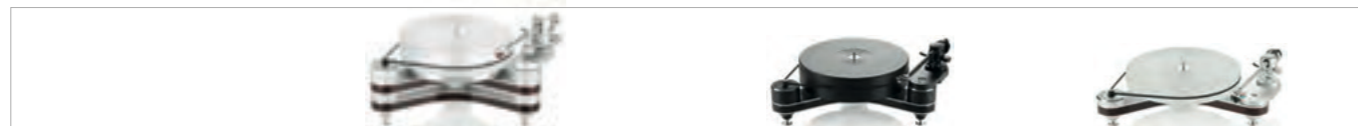

Model:	Innovation	Innovation Compact	Innovation Basic
Construction details:	- Resonance-optimised chassis shape - Made of bullet proof wood and aluminium - All turntable feet are finely adjustable - Playback with two tonearms possible	- Resonance-optimised chassis shape - Made of bullet proof wood and aluminium - All turntable feet are finely adjustable - Playback with two tonearms possible	- Resonance-optimised chassis shape - Made of bullet proof wood and aluminium - All turntable feet are finely adjustable - Playback with two tonearms possible
Speed options:	33 1/3, 45, 78rpm	33 1/3, 45, 78rpm	33 1/3, 45, 78rpm
Drive unit:	- High torque 24V DC motor, belt-drive - Optical Speed Control (OSC) in real time through infrared sensor	- High torque 24V DC motor; belt drive - Optical Speed Control (OSC) in real time through infrared sensor	- High torque 24V DC motor; belt drive - Optical Speed Control (OSC) in real time through infrared sensor
Bearing:	Inverted bearing in lower drive platter. Clearaudio CMB ceramic magnetic bearing in main platter / upper drive platter assembly.	Inverted bearing in lower drive platter. Clearaudio CMB ceramic magnetic bearing in main platter / upper drive platter assembly.	Inverted bearing in lower drive platter. Clearaudio CMB ceramic magnetic bearing in main platter / upper drive platter assembly.
Platter:	70mm / 2.75 inch main platter, made out of synthetic material with high-density and excellent dimension stability, precision CNC machined surface, solid stainless steel sub-platter, dynamically balanced	70mm / 2.75 inch main platter, made out of synthetic material with high-density and excellent dimension stability, precision CNC machined surface, solid stainless steel sub-platter, dynamically balanced	40mm / 1.57 inch main platter, made out of synthetic material with high-density and excellent dimension stability, precision CNC machined surface, solid stainless steel sub-platter, dynamically balanced
Speed accuracy (measured):	< ± 0.05%	< ± 0.08%	< ± 0.08%
Power consumption:	Max. consumption: 9.3 watts Consumption in operation: 2.5 watts Standby mode: 2.5 watts Off mode: 0.0 watts	Max. consumption: 9.3 watts Consumption in operation: 2.5 watts Standby mode: 2.5 watts Off mode: 0.0 watts	Max. consumption: 9.3 watts Consumption in operation: 2.5 watts Standby mode: 2.5 watts Off mode: 0.0 watts
Total weight:	Approx. 24kg (without tonearm and power supply)	Approx. 12kg (without tonearm and power supply)	Approx. 8kg (without tonearm and power supply)
Dimensions (W/D/H):	Approx. 18.11 x 19.09 x 8.66 inches (with tonearm base, without tonearm)	Approx. 18.11 x 19.09 x 6.18 inches (with tonearm base, without tonearm)	Approx. 18.11 x 19.09 x 4.92 inches (with tonearm base, without tonearm)
Dimensions (W/D/H):	Approx. 460 x 485 x 220mm (with tonearm base, without tonearm)	Approx. 460 x 485 x 157mm (with tonearm base, without tonearm)	Approx. 460 x 485 x 125mm (with tonearm base, without tonearm)
Manufacturer's warranty:	5 years*	5 years*	5 years*



Model:	concept Signature	Compass
Construction details:	- Resonance-optimised turntable - Upper layer incorporates high-tech satined plastic compound - Chassis comprises medium-density wood fibre (silver / black) or pressure-formed solid wood (wood / dark wood) - Bottom plate medium-density wood fibre - Height-adjustable turntable feets	- Resonance-optimised turntable - Turntable chassis comprises medium-density wood fibre (silver / black) - Steel bottom plate for additional weight - Including decoupling elements
Speed options:	33 1/3, 45rpm	33 1/3, 45rpm
Drive unit:	- Decoupled and resonance damped 12V DC motor - Flat belt-drive - Plug-in power supply unit, designed for worldwide use with all networks and power frequencies. - „IMS light – Innovative Motor Suspension“ (Suspension design of the motor using O-rings) - „TSC - Tacho Speed Control“ (Speed monitoring - Automatic compensation of friction and temperature changes on platter bearings and belts)	- Decoupled and resonance damped 12V DC motor - Flat belt-drive - Plug-in power supply unit, designed for worldwide use with all networks and power frequencies
Bearing:	Polished and tempered steel spindle in a sintered bronze bushing, running on a teflon thrust-pad.	Polished and tempered steel spindle in a sintered bronze bushing, running on a teflon thrust-pad.
Platter:	30mm / 1.18 inch main platter, made out of synthetic material with high-density and excellent dimension / precision CNC machined aluminium sub-platter.	20mm / 0.787 inches main platter, made out of acrylic with excellent dimension stability / precision CNC machined aluminium sub-platter.
Speed accuracy (measured):	± 0.05%	± 0.05%
Power consumption:	Max. consumption: 3.6 watts Consumption in operation: 1.92 watts Standby: 0.74 watts Off mode: 0.0 watts (switched off at the rear)	Max. consumption: 4 watts Consumption in operation: 1.95 watts Standby: 0.74 watts Off mode: 0.0 watts (switched off at the bottom)
Total weight:	Approx. 7.5kg (incl. tonearm and cartridge)	Approx. 8kg (incl. tonearm and cartridge)
Dimensions (W/D/H):	Approx. 16.54 x 13.78 x 4.92 inches (with tonearm)	Approx. 17.13 x 13.39 x 4.72 inches (incl. Dustcover)
Dimensions (W/D/H):	Approx. 420 x 350 x 125mm (with tonearm)	Approx. 435 x 340 x 120mm (incl. dustcover)
Manufacturer's warranty:	2 years*	2 years*

*Provided the warranty card is fully completed and returned to Clearaudio or registered online within 2 weeks of purchase. More information about the power consumption of our products on www.clearaudio.de

*Provided the warranty card is fully completed and returned to Clearaudio or registered online within 2 weeks of purchase. More information about the power consumption of our products on www.clearaudio.de

Technical Specifications

Tonearms I



Model:	TT1	TT1 MI
Construction details:	Tangential tonearm Mechanical and passive drive through dry-running ball bearing in an calibrated polished glass tube	Tangential tonearm Mechanical and passive drive through dry-running ball bearing in an calibrated polished glass tube
Material:	Aluminium (black/silver), stainless steel, bullet proof wood (natural/black), glass	Aluminium (black/silver), stainless steel, bullet proof wood (natural/black), glass
Cartridge balance range:	5.5g - 15g	5.5g - 15g
Mounting style:	On request	On request
Wiring:	2m Super Sixstream terminated with RCA	2m Super Sixstream terminated with RCA
Weight:	Approx. 8.6kg, incl. armwand	Approx. 8.2kg
Dimensions (W/D/H):	Approx. 21.26 x 8.27 x 8.27 inches	Approx. 21.26 x 8.27 x 7.68 inches
Dimensions (W/D/H):	Approx. 540 (incl. lift unit) x 210 x 210mm	Approx. 540 (incl. lift unit) x 210 x 195mm
Manufacturer's warranty:	10 years*	5 years*



Model:	TT2	TT3	TT5
Construction details:	Tangential tonearm Mechanical and passive drive through dry-running ball bearing in an calibrated polished glass tube	Tangential tonearm Mechanical and passive drive through dry-running ball bearing in an calibrated polished glass tube	Tangential tonearm Mechanical and passive drive through dry-running ball bearing in an calibrated polished glass tube
Material:	Aluminium (black/silver), stainless steel, glass	Aluminium (black/silver), stainless steel, glass	Aluminium (black/silver), stainless steel, glass
Cartridge balance range:	5.5g - 15g	5.5g - 15g	5.5g - 15g
Mounting style:	On request	On request	On request
Wiring:	2m Super Sixstream terminated with RCA	- RCA connection - Super Sixstream terminated with RCA (1.0 / 1.5m) - Direct Wire terminated with RCA (1.0 / 1.5m)	1.1m Super Sixstream terminated with RCA
Weight:	Approx. 2kg (without tonearm base); tonearm base only: approx. 245g	Approx. 690g (without tonearm base); tonearm base only: approx. 245g	Approx. 520g (without aluminium collar); Collar only: 65g
Dimensions (W/D/H):	Approx. 11.81 x 4.33 x 2.56 inches (without folding base; without height adjustment screw)	Approx. 10.83 x 3.74 x 1.77 inches (without folding base; without height adjustment screw)	Approx. 7.87 x 5.51 x 5.51 inches (incl. headshell)
Dimensions (W/D/H):	Approx. 300 x 110 x 65mm (without folding base; without height adjustment screw)	Approx. 275 x 95 x 45mm (without folding base; without height adjustment screw)	Approx. 200 x 140 x 140mm (incl. headshell)
Manufacturer's warranty:	5 Jahre*	5 years*	5 years*



Model:	Unity (10 inch)	Universal (9 and 12 inch)
Construction details:	Radial tonearm with magnetically stabilized single-point sapphire bearing. Available in 10 inches.	Radial tonearm using ultra low friction bearings Available in 9 and 12 inches.
Material:	Aluminium (black/silver), stainless steel, carbon tonearm tube (black/silver)	Aluminium (black/silver), stainless steel, carbon tonearm tube (black/silver)
Cartridge balance range:	5.0 - 17.0g	9 inch: 2.9g - 24.8g // 12 inch: 2.9g - 21.0g
Effective mass:	16g	-
Overhang:	16.22mm	9 inch: 17.00mm // 12 inch: 13.01mm
Total length:	370mm	9 inch: 345.00mm // 12 inch: 420.00mm
Effective length:	254mm	9 inch: 239.00mm // 12 inch: 308.01mm
Mounting distance (tonearm pivot to spindle):	238mm	9 inch: 222.00mm // 12 inch: 295.00mm
Offset angle:	21.59°	9 inch: 24.89° // 12 inch: 18.85°
Wiring:	"1.1m Clearaudio Super Sixstream terminated with RCA / Alternativ with DIN connector"	1.1m Clearaudio Super Sixstream terminated with RCA
Weight:	790g (without counterweight)	9 inch: approx. 745g (incl. counterweight) 12 inch: approx. 760g (incl. counterweight)
Manufacturer's warranty:	2 years*	5 years*

Tonearms II



Model:	Tracer (9 inch)	Profiler (9 inch)
Construction details:	Radial tonearm Horizontal sapphire bearing and vertically ball bearing	Radial tonearm Horizontal sapphire bearing and vertically ball bearing
Material:	Aluminium (black/silver), stainless steel, carbon tonearm tube (black/silver)	Aluminium (black/silver), stainless steel, aluminium tonearm tube (black/silver)
Cartridge balance range:	3.5g - 17.0g	3.5g - 17.0g
Overhang:	17.12mm	17.58mm
Total length:	320.00mm	300.00mm
Effective length:	239.12mm	239.58mm
Mounting distance (tonearm pivot to spindle):	222.00mm	222.00mm
Offset angle:	25.00°	24.5°
Wiring:	1.1m Super Sixstream terminated with RCA	1.1m Direct Wire PLUS terminated with RCA
Weight:	Approx. 500g (incl. counterweight)	Approx. 510g (incl. counterweight)
Manufacturer's warranty:	3 years*	2 years*



Model:	Satisfy Kardan (9 inch)	Satisfy Kardan Signature (9 inch)
Construction details:	Radial tonearm With magnetic antiskating	Radial tonearm With magnetic antiskating
Material:	Aluminium (black/silver), stainless steel, tonearm tube made of aluminium (black/silver)	Aluminium (black/silver), stainless steel, tonearm tube made of carbon (black/silver)
Cartridge balance range:	2.5g - 17.0g	2.5g - 17.0g
Overhang:	17.12mm	17.12mm
Total length:	305.00mm	305.00mm
Effective length:	239.12mm	239.12mm
Mounting distance (tonearm pivot to spindle):	222.00mm	222.00mm
Offset angle:	24.02°	24.02°
Wiring:	1.1m Clearaudio Direct Wire PLUS terminated with RCA	1.1m Clearaudio Direct Wire PLUS terminated with RCA
Weight:	Approx. 490g (incl. counterweight)	Approx. 490g (incl. counterweight)
Manufacturer's warranty:	2 years*	2 years*



Model:	Clarify (9 inch)	concept / Verify (9 inch)
Construction details:	Radial tonearm With friction free magnetic bearing technology	Radial tonearm With friction free magnetic bearing technology
Material:	Aluminium (silver), stainless steel, carbon tonearm tube (silver)	Aluminium (silver), tonearm tube made of black aluminium (concept) or silver carbon (Verify)
Cartridge balance range:	2.5g - 17.0g	2.5g - 17.0g
Overhang:	17.33mm	17.56mm
Total length:	330.00mm	305.00mm
Effective length:	239.25mm	239.56mm
Mounting distance (tonearm pivot to spindle):	222.00mm	222.00mm
Offset angle:	25.45°	24.16°
Wiring:	1.1m Clearaudio Direct Wire PLUS terminated with RCA	1.1m Clearaudio Direct Wire PLUS terminated with RCA
Weight:	Approx. 410g (incl. counterweight)	concept: approx. 450g (incl. counterweight) Verify: approx. 440g (incl. counterweight)
Manufacturer's warranty:	2 years*	2 Jahre*

*Provided the warranty card is fully completed and returned to Clearaudio or registered online within 2 weeks of purchase. More information about the power consumption of our products on www.clearaudio.de

*Provided the warranty card is fully completed and returned to Clearaudio or registered online within 2 weeks of purchase. More information about the power consumption of our products on www.clearaudio.de

Technical Specifications

Electronics-I



Model:	statement phono		
Mode:	MM / MC switchable // Subsonic filter switchable	Outputs:	unbalanced (RCA) balanced (XLR) headphone output (Jack: 6.3mm)
Amplification:	+ 34dB (MM mode) + 54dB (MC mode)	Power consumption:	Max. consumption: 200 watts In operation: 50 - 100 watts Standby mode: < 0.5 watts Off mode: 0.0 watts
Input load:	47kΩ (MM mode) 25Ω - 10kΩ (MC mode)	Power supply:	Fully symmetrical line and Accu - power supply
RIAA accuracy:	± 0.05dB / 20 - 100kHz	Main power / channel:	2 x 2 x 22V / 1A
THD:	5mV / 1kHz / +50dB: < 0.0035% 0.5mV / 1kHz / +70dB: < 0.0015%	Battery power / channel:	2 x 18V / 3.2Ah
Signal to noise ratio:	5mV / 1kHz / +50dB: -82dB / -90dB (A-weighted) 0.5mV / 1kHz / +70dB: -72dB / -80dB (A-weighted)	Total weight preamplifier:	Approx. 12kg
Headroom:	+ 25dB	Total weight power supply:	Approx. 22kg
Max. output voltage:	> 12V	Dimensions preamplifier (W/D/H):	Approx. 17.13 x 13.78 x 3.94 inches
RIAA:	75µs / 318µs / 3180µs, 2 passive filter	Dimensions preamplifier (W/D/H):	Approx. 435 x 350 x 100mm
Channel separation:	> 80dB (at 1kHz)	Dimensions power supply (W/D/H):	Approx. 17.13 x 13.78 x 3.94 inches
Output impedance:	10Ω	Dimensions power supply (W/D/H):	Approx. 435 x 350 x 100mm
Inputs:	Phono 1: balanced XLR (rear) Phono 2: unbalance RCA (rear) Line 1: balanced XLR (rear) Line 2: unbalanced RCA (rear) AUX: Jack 3.5mm (front)	Manufacturer's warranty:	5 years*

Electronics-II



Model:	balance V2		
Mode:	MM / MC switchable (at bottom) // Subsonic filter switchable (at bottom) 20Hz (-6dB / Oct.; on each channel)	Inputs:	unbalanced (RCA) balanced (XLR)
Amplification:	+ 46dB (MM mode) + 66dB (MC mode)	Outputs:	unbalanced (RCA) balanced (XLR) headphone output (Jack 6.3mm)
Input load:	47kΩ / 270pF (MM mode) 500Ω / 270pF (MC mode)	Power consumption:	Max. consumption: 6.6 watts Standby mode: < 0.3 watts Off mode: 0.0 watts
RIAA accuracy:	± 0.1dB	Power supply:	± 18V DC (+ 21V DC external power supply; 1.4m cable length)
THD:	< 0.001% (IEC A)	Total weight preamplifier:	Approx. 2.3kg
Signal to noise ratio:	- 78dB (MM mode) - 79dB (MC mode)	Total weight power supply:	Approx. 1.4kg
Headroom:	+ 23dB	Dimensions preamplifier (W/D/H):	Approx. 9.44 x 5.71 x (6.22 with RCA) x 2.44 inches
Max. output voltage:	> 12V (at 1kHz)	Dimensions preamplifier (W/D/H):	Approx. 240 x 145 (158 with RCA) x 62mm
RIAA:	75µs / 318µs / 3180µs, 2 passive filter	Dimensions power supply (W/D/H):	Approx. 9.44 x 5.71 x 2.44 inches
Channel separation:	> 92dB (at 1kHz)	Dimensions power supply (W/D/H):	Approx. 240 x 145 x 62mm
Output impedance:	150Ω (balanced XLR) 75Ω (unbalanced RCA)	Manufacturer's warranty:	3 years*



Model:	balance reference phono		
Mode:	MM / MC switchable (at bottom) // Subsonic filter switchable @20Hz (-18dB / Oct) (at bottom) // Stereo / Mono switchable	Inputs:	unbalanced (RCA) balanced (XLR)
Amplification:	+ 46dB (MM mode) + 66dB (MC mode)	Outputs:	unbalanced (RCA) balanced (XLR) headphone output (2x Jack: 6.3mm)
Input load:	50kΩ / 50pF (MM mode and MC mode) +150pF, +270pF, +400pF (MM mode) 10kΩ, 5kΩ, 1000Ω, 500Ω, 100Ω, 50Ω (MC mode)	Power consumption:	Max. consumption: 12 watts Standby mode: < 0.5 watts Off mode: 0.0 watts (turn off at the rear)
RIAA accuracy:	± 0.1dB @ 20Hz - 100kHz	Power supply:	2x ± 18V DC (external power supply) 2x +/- 21V DC, 1.4m cable length
THD:	< 0.001% (IEC A)	Total weight preamplifier:	Approx. 2.9kg
Signal to noise ratio:	- 89dB @ 5mV / MM mode (IEC A) - 79dB @ 500µV / MC mode (IEC A)	Total weight power supply:	Approx. 2.2kg
Headroom:	> + 21dB @ 1kHz	Dimensions preamplifier (W/D/H):	Approx. 9.45 x 5.71 x 3.07 inches (6.22 inches depth with RCA)
Max. output voltage:	> 12V	Dimensions preamplifier (W/D/H):	Approx. 240 x 145 x 78mm (158mm depth with RCA)
RIAA:	75µs / 318µs / 3180µs, 2 passive filter	Dimensions power supply (W/D/H):	Approx. 9.45 x 5.71 x 3.07 inches
Channel separation:	> 95dB @ 1kHz (IEC A)	Dimensions power supply (W/D/H):	Approx. 240 x 145 x 78mm
Output impedance:	150Ω (balanced XLR) 75Ω (unbalanced RCA)	Manufacturer's warranty:	3 years*



Model:	basic V2		
Mode:	MM / MC switchable (at bottom) // Subsonic filter switchable (at bottom) 20Hz (-18dB / Oct.; on each channel)	Output impedance:	10Ω
Amplification:	+ 46dB (MM mode) + 66dB (MC mode)	Inputs:	unbalanced (RCA)
Input load:	47kΩ / 270pF (MM mode) 500Ω / 270pF (MC mode)	Outputs:	unbalanced (RCA)
RIAA accuracy:	± 0.1dB	Power consumption:	Max. consumption: 3 watts (in operation) Standby mode: < 0.3 watts
THD:	< 0.002% (IEC A)	Power supply:	± 18V DC (external wall mount power supply; 1.4m cable length)
Signal to noise ratio:	- 72dB (MM mode) - 67dB (MC mode)	Total weight:	Approx. 1.2kg (preamp and power supply)
Headroom:	+ 20dB	Dimensions (W/D/H):	Approx. 4.65 x 5.71 (6.22 with RCA) x 1.65 inches
Max. output voltage:	> 10V (at 1kHz)	Dimensions (W/D/H):	Approx. 118 x 145 (158 with RCA) x 42mm
RIAA:	75µs / 318µs / 3180µs, 2 passive filter	Manufacturer's warranty:	3 years*
Channel separation:	> 90dB at 1kHz		

*Provided the warranty card is fully completed and returned to Clearaudio or registered online within 2 weeks of purchase. More information about the power consumption of our products on www.clearaudio.de

*Provided the warranty card is fully completed and returned to Clearaudio or registered online within 2 weeks of purchase. More information about the power consumption of our products on www.clearaudio.de

Technical Specifications

Electronics-III



Model:		smart phono V2	
Mode:	MM / MC switchable by jumpers (at bottom) // Subsonic filter switchable by jumpers (at bottom)	Output impedance:	75Ω
Amplification:	34dB (MM mode) 54dB (MC mode)	Inputs:	unbalanced (RCA)
Input load:	50Ω, 100Ω, 500Ω, 1 kΩ, 5kΩ / 150pF, 250pF, 400pF (MC mode) 47kΩ / 150pF, 250pF, 400pF (MM mode)	Outputs:	unbalanced (RCA) optional headphone output (Jack: 3.5mm)
RIAA accuracy:	± 0.3dB @ 10Hz - 100kHz	Power consumption:	Max. consumption: 2.7 watts Consumption in operation: 2.7 watts Off mode: 0.0 watts
THD:	< 0.004% MC ("A" @ 1kHz / -1dB @ MAX)	Power supply:	± 18V DC / 300mA (external power supply)
Signal to noise ratio:	85dB (A) (MM mode) 72dB (A) (MC mode)	Total weight:	Approx. 620g (Preamp and power supply)
Headroom:	18dB / MC (Gain Control on MAX)	Dimensions (W/D/H):	Approx. 3.74 x 4.92 x 1.34 inches
Max. output voltage:	10V eff. (1kHz)	Dimensions (W/D/H):	Approx. 95 x 125 x 34mm
RIAA:	delay time: 75µs / 318µs / 3180µs	Manufacturer's warranty:	3 years*
Channel separation:	> 90dB @ 1kHz		

Electronics-IV



Model:	smart power 24V	smart power 12V
Battery:	NiMh Battery with 5000mAh	NiMh Battery 12V 5000mAh
Power supply:	100 - 240V AC, 50 - 60Hz, max. 1.6A	100-240V AC, 50 - 60Hz, max. 1.6A
Output:	24V DC, max. 1.6A, fused (time delay fuse)	12V DC, max. 1.6A; fused (time delay fuse)
Power consumption:	Operation mode: 6.5 - 33 watts (depending on the charge cycle) Off mode: 0 watts (turned off at rear panel)	Operation mode: 6.5 - 33 watts (depending on the charge cycle) Off mode: 0 watts (turned off at rear panel)
Total weight:	Approx. 5.7kg	Approx. 2.2kg
Dimensions (W/D/H):	Approx. 8.27 x 12.00 x 4.92 inches	Approx. 4.33 x 13.78 x 1.81 inches
Dimensions (W/D/H):	Approx. 210 x 305 x 125mm	Approx. 110 x 350 x 46mm
Manufacturer's warranty:	3 years* (except batteries)	2 years* (except batteries)



Modell:	Professional Power 24V	Professional Power 12V
Power supply:	110V AC 60Hz, max. 200mA (time delay fuse) 240V AC, 50Hz, max. 200mA (time delay fuse)	110V AC 60Hz, max. 200mA (time delay fuse) 240V AC, 50Hz, max. 200mA (time delay fuse)
Output:	24V, max. 500mA; fused (time delay fuse)	12V, max. 500mA; fused (time delay fuse)
Power consumption:	In operation: 33.3rpm > 3.0 watts 45rpm > 3.1 watts 78rpm > 3.3 watts (switched on at the rear „I“) Off mode: 0.0 watts (turned off at rear panel „0“)	In operation (LED on): 0rpm > 1.1 watts 33.3rpm > 1.4 watts 45rpm > 1.5 watts 78rpm > 1.7 watts Standby (LED off) = 1 watt Off mode: 0.0 watts (turned off at rear panel „0“) Ripple voltage = 50µVPP
Total weight:	Approx. 1.10kg	Approx. 813g
Dimensions (W/D/H):	Approx. 3.62 x 5.71 x 3.70 inches	Approx. 2.87 x 5.71 x 2.99 inches
Dimensions (W/D/H):	Approx. 92 x 145 x 94mm	Approx. 73 x 145 x 76mm
Manufacturer's warranty:	2 years*	2 years*



Model:		nano phono V2	
Mode:	MM / MC switchable by jumpers (at bottom) // Subsonic filter switchable by jumpers (at bottom)	Output impedance:	75Ω
Amplification:	34dB (MM mode) 54dB (MC mode)	Inputs:	unbalanced (RCA)
Input load:	47kΩ / 220pF / MM mode User MC mode	Outputs:	unbalanced (RCA) optional headphone output (Jack: 3.5mm)
RIAA accuracy:	± 0.4dB @ 20Hz - 50kHz	Power consumption:	Max. consumption: 2.3 Watt In operation: 2.3 Watt Standby mode: < 0.3 Watt Off mode: 0.0 Watt
THD:	< 0.04%	Power supply:	± 18V DC / 300mA (external power supply)
Signal to noise ratio:	81dB (A) (MM mode) 70dB (A) (MC mode)	Total weight:	Approx. 500g (Preamp and power supply)
Headroom:	18dB / MC	Dimensions (W/D/H):	Approx. 3.35 x 4.17 x 0.98 inches
Max. output voltage:	10V eff (1 kHz)	Dimensions (W/D/H):	Approx. 85 x 106 x 25mm
RIAA:	Nach RIAA (Zeitkonst.: 75µs / 318µs / 3180µs)	Manufacturer's warranty:	3 years*
Channel separation:	> 80dB @ 1kHz		



Modell:	Power Terminal
Nominal input voltage:	230V AC / 50Hz
Nominal output voltage:	230V AC / 50Hz
Total load capacity:	2.500W bei 230V AC / 50Hz
Output load capacity:	1x 100W max. (0,5A bei 230VAC) 2x 800W max. (4A bei 230VAC) 2x 200W max. (1A bei 230VAC) 2x 200W max. (1A bei 230VAC)
Dimensions (W/D/H):	2.36 x 3.15 x 17.87 inches
Dimensions (W/D/H):	60 x 80 x 454mm
Cable length power cord:	1.5m
Weight:	Approx. 3.1kg
Warranty:	3 years*



Modell:	Terra
Connections:	- 3x Ground connection without potential difference - 3x Ground connection with potential difference - IEC socket
Weight:	Approx. 1.500g (without power cord)
Dimensions (W/D/H):	Approx. 3.54 x 5.79 x 3.66 inches
Dimensions (W/D/H):	Approx. 90 x 147 x 93mm
Manufacturer's warranty:	2 years*

*Provided the warranty card is fully completed and returned to Clearaudio or registered online within 2 weeks of purchase. More information about the power consumption of our products on www.clearaudio.de

*Provided the warranty card is fully completed and returned to Clearaudio or registered online within 2 weeks of purchase. More information about the power consumption of our products on www.clearaudio.de

Technical Specifications

Cartridges MC



Model:	Goldfinger Statement V2.1	Titanium V2	da Vinci V2	Jubilee MC	Stradivari V2
Total mass:	~ 15.0g (± 2g)	10.0g	6.8g	7.5g	7.0g
Frequency response:	20Hz - 20kHz	20Hz - 20kHz	20Hz - 20kHz	20Hz - 20kHz	20Hz - 20kHz
Output voltage (at 5cm/sec):	0.5 - 0.6mV	0.5mV	0.5mV	0.5mV	0.5mV
Channel separation:	> 32dB	> 30dB	25 - 30dB	> 32dB	25 - 30dB
Channel balance:	< 0.2dB	< 0.3dB	< 0.5dB	< 0.5dB	< 0.5dB
Tracking ability:	90µm	90µm	80µm	80µm	80µm
Recommended tracking force:	2.8g (± 0.2g)	2.8g (± 0.2g)	2.8g (± 0.2g)	2.8g (± 0.2g)	2.8g (± 0.2g)
Cartridge impedance:	50Ω	50Ω	50Ω	50Ω	50Ω
Cantilever / stylus shape:	Boron / Clearaudio Prime Line PLUS	Boron / Clearaudio Prime Line	Boron / Clearaudio Prime Line	Boron / Clearaudio Prime Line	Boron / Clearaudio Prime Line
Compliance:	15µ/mN	15µ/mN	15µ/mN	15µ/mN	15µ/mN
Coil assembly:	Absolutely symmetrical design	Absolutely symmetrical design	Absolutely symmetrical design	Absolutely symmetrical design	Absolutely symmetrical design
Coil material:	24 carat gold	24 carat gold	24 carat gold	24 carat gold	24 carat gold
Cartridge body:	14 carat gold	Titanium	Aluminium with 30 micron ceramic coating	Bullet proof wood	Ebony wood
Manufacturer's warranty:	2 years*	2 years*	2 years*	2 years*	2 years*

Cartridges MM



Model:	Charisma V2	Maestro V2	Virtuoso V2	Jubilee MM
Total mass:	9.0g (± 1g)	8.4g (± 0.4g)	8.4g (± 0.4g)	8.8g (± 0.4g)
Frequency response:	20Hz - 20kHz	20Hz - 20kHz	20Hz - 20kHz	20Hz - 20kHz
Output voltage (1kHz, 5cm/s):	~ 3.6mV	~ 3.6mV	~ 3.6mV	~ 3.6mV
Channel separation (1kHz):	30dB	25dB	26dB	26dB
Channel balance (1kHz):	0.2dB	0.3dB	0.4dB	0.4dB
Tracking ability:	90µm	80µm	80µm	90µm
Recommended tracking force:	2.4g (± 0.3g)	2.2g (± 0.3g)	2.2g (± 0.3g)	2.2g (± 0.3g)
Coil impedance (1kHz):	0.66kΩ	0.66kΩ	0.66kΩ	0.66kΩ
Coil inductance:	400mH	400mH	400mH	400mH
Load resistance:	47kΩ	47kΩ	47kΩ	47kΩ
Load capacitance:	100pF	100pF	100pF	100pF
Cantilever / stylus shape:	Boron / Clearaudio Prime Line	Boron / Shibata	Aluminium / elliptical	Aluminium / elliptical
Compliance:	17µ/mN	16µ/mN	15µ/mN	15µ/mN
Cartridge body:	Ebony wood with German Silver inlay	Ebony wood	Ebony wood	Bullet proof wood
Manufacturer's warranty:	2 years*	2 years*	2 years*	2 years*



Model:	Concerto V2	Talisman V2 Gold	concept mc Signature	concept mc
Total mass:	7.0g	10.6 - 11.2g	8.0g	8.0g
Frequency response:	20Hz - 20kHz	20Hz - 20kHz	20Hz - 20kHz	20Hz - 20kHz
Output voltage (at 5cm/sec):	0.5mV	0.5mV	0.4mV	0.4mV
Channel separation:	25 - 30dB	25 - 30dB	> 30dB	> 28dB
Channel balance:	< 0.5dB	< 0.5dB	< 0.3dB	< 0.5dB
Tracking ability:	80µm	80µm	80µm	80µm
Recommended tracking force:	2.8g (± 0.2g)	2.8g (± 0.2g)	2.2g (± 0.2g)	2.2g (± 0.2g)
Cartridge impedance:	50Ω	50Ω	11Ω	11Ω
Cantilever / stylus shape:	Boron / Clearaudio Prime Line	Boron / Clearaudio Prime Line	Boron / Micro Line	Boron / Micro Line
Compliance:	15µ/mN	15µ/mN	9µ/mN	9µ/mN
Coil assembly:	Absolutely symmetrical design	Absolutely symmetrical design	—	—
Coil material:	24 carat gold	24 carat gold	OFC – copper	OFC - copper
Cartridge body:	Satiné wood	Hand polished ebony wood body	Aluminium-magnesium alloy with ceramic surface layer	Aluminium-magnesium alloy with ceramic surface layer
Manufacturer's warranty:	2 years*	2 years*	2 years*	2 years*



Model:	Artist V2	Performer V2	concept V2
Total mass:	8.4g (± 0.4g)	8.4g (± 0.4g)	8.6g (± 0.2g)
Frequency response:	20Hz - 20kHz	20Hz - 20kHz	20Hz - 20kHz
Output voltage (1kHz, 5cm/s):	~ 3.6mV	~ 3.3mV	~ 3.3mV
Channel separation (1kHz):	24dB	20dB	20dB
Channel balance (1kHz):	0.8dB	1.5dB	2dB
Tracking ability:	80µm	80µm	80µm
Recommended tracking force:	2.2g (± 0.3g)	2.2g (± 0.3g)	2.2g (± 0.3g)
Coil impedance (1kHz):	0.66kΩ	0.66kΩ	0.66kΩ
Coil inductance:	400mH	400mH	400mH
Load resistance:	47kΩ	47kΩ	47kΩ
Load capacitance:	100pF	100pF	100pF
Cantilever / stylus shape:	Aluminium / elliptical	Aluminium / elliptical	Aluminium / elliptical
Compliance:	15µ/mN	15µ/mN	15µ/mN
Cartridge body:	Ebony wood	Ebony wood	Aluminium
Manufacturer's warranty:	2 years*	2 years*	2 years*

*Provided the warranty card is fully completed and returned to Clearaudio or registered online within 2 weeks of purchase. More information about the power consumption of our products on www.clearaudio.de

*Provided the warranty card is fully completed and returned to Clearaudio or registered online within 2 weeks of purchase. More information about the power consumption of our products on www.clearaudio.de

Technical Specifications

Record cleaning machines



Model:	double matrix professional SONIC
Main features:	<ul style="list-style-type: none"> - Left and right turning - Cleaning of both sides - Vacuum engine with overheat sensor - Integrated antistatic brushes device for discharge of static charge - Automatic fluid application - Sonic option – gentle and high efficient cleaning through vibration - Automatic cleaning process with only one button - Optional manual control of each cleaning step
Power consumption:	Max. consumption: Approx. 450 watts Off mode: 0 watts (by switching off at the rear of the machine)
Weight:	Approx. 16kg
Dimensions (W/D/H):	Approx. 16.14 x 15.16 x 10.87 inches (incl. record clamp) Approx. 16.14. x 15.16 x 11.42 inches (with acrylic dustcover)
Dimensions (W/D/H):	Approx. 410 x 385 x 276mm (incl. record clamp) Approx. 410 x 385 x 290mm (with acrylic dustcover)
Manufacturer's warranty:	3 years*



Modell:	smart double matrix
Main features:	<ul style="list-style-type: none"> - Cleaning of both sides - Cleaning of 7, 10 and 12 inch records possible - Left and right turning - Automatic fluid application - Manual control of each cleaning step - Antistatic brush unit to discharge of static electricity
Power consumption:	Max. consumption: Approx. 190 watts Off mode: 0 watts (by switching off at the rear of the machine)
Weight:	Approx. 5.4kg
Dimensions (W/D/H):	Approx. 8.66 x 11.42 x 8.27 inches (incl. record clamp)
Dimensions (W/D/H):	Approx. 220 x 290 x 210mm (incl. record clamp)
Manufacturer's warranty:	3 years*

Accessories



Model:	Innovation Series Stand		
Construction details:	Made of bullet proof wood and aluminium Caps made of stainless steel	Total weight:	Approx. 35kg



*Provided the warranty card is fully completed and returned to Clearaudio or registered online within 2 weeks of purchase. More information about the power consumption of our products on www.clearaudio.de

*Provided the warranty card is fully completed and returned to Clearaudio or registered online within 2 weeks of purchase. More information about the power consumption of our products on www.clearaudio.de

Find out more about Clearaudio products

Please see our English language website at:
www.clearaudio.de for full details of all Clearaudio products or you can contact
your local Clearaudio distributor or dealer
(listings of international distributors/dealers are given on our website.)

Acknowledgements

Concept, artwork and production by:
AUFSESS Kommunikation GmbH, Nuremberg, Germany www.aufsess.com

Photo credits:

- Cover, 58/59: Radek Grzybowski, unsplash
- 5: Thomas Riese
- 6/7: Arindam Mahanta, unsplash
- 20/21, 34/35, 48/49, 82/83, Back cover: Lucja Romanowska
- 102/103: Suteishi, getty images
- Product photos: Christian Schleupner

Disclaimer

Technical specifications are subject to change or improvement without prior notice.

Clearaudio accepts no liability for any misprints.

Product availability as long as stock lasts.

© Clearaudio Electronic GmbH 2025

Use of any of the text or images contained in this brochure requires written confirmation from Clearaudio Electronic GmbH.

Protective charge: EUR 15,-



Loving music



Clearaudio electronic GmbH 2025

Spardorfer Str. 150 | D-91054 Erlangen | Fon: +49.9131.40 300 100 | Fax: +49.9131.40 300 119 | info@clearaudio.de
Made in Germany | www.clearaudio.de | www.analogshop.de

#250207-E
aufsess.com

Foto: Lucja Romanowska